

PHILIPS

Data handbook



Electronic
components
and materials

Electron tubes

Part 6 January 1977

Channel electron multipliers

Geiger-Mueller tubes

Neutron tubes

Semiconductor radiation detectors

ELECTRON TUBES

Part 6

January 1977

Channel electron multipliers

Geiger-Mueller tubes

Neutron tubes

Semiconductor radiation detectors

Index



RATING SYSTEM

ABSOLUTE MAXIMUM RATING SYSTEM

Absolute maximum ratings are limiting values of operating and environmental conditions applicable to any electronic device of a specified type as defined by its published data, which should not be exceeded under the worst probable conditions.

These values are chosen by the device manufacturer to provide acceptable serviceability of the device, taking no responsibility for equipment variations, environmental variations, and the effects of changes in operating conditions due to variations in the characteristics of the device under consideration and of all other electronic devices in the equipment.

The equipment manufacturer should design so that, initially and throughout life, no absolute maximum value for the intended service is exceeded with any device under the worst probable operating conditions with respect to supply voltage variation, equipment component variation, equipment control adjustment, load variations, signal variation, environmental conditions, and variations in characteristics of the device under consideration and of all other electronic devices in the equipment.

DATA HANDBOOK SYSTEM

Our Data Handbook System is a comprehensive source of information on electronic components, subassemblies and materials; it is made up of three series of handbooks each comprising several parts.

ELECTRON TUBES

BLUE

SEMICONDUCTORS AND INTEGRATED CIRCUITS

RED

COMPONENTS AND MATERIALS

GREEN

The several parts contain all pertinent data available at the time of publication, and each is revised and reissued periodically.

Where ratings or specifications differ from those published in the preceding edition they are pointed out by arrows. Where application information is given it is advisory and does not form part of the product specification.

If you need confirmation that the published data about any of our products are the latest available, please contact our representative. He is at your service and will be glad to answer your inquiries.

This information is furnished for guidance, and with no guarantee as to its accuracy or completeness; its publication conveys no licence under any patent or other right, nor does the publisher assume liability for any consequence of its use; specifications and availability of goods mentioned in it are subject to change without notice; it is not to be reproduced in any way, in whole or in part without the written consent of the publisher.

ELECTRON TUBES (BLUE SERIES)

This series consists of the following parts, issued on the dates indicated.

Part 1a	Transmitting tubes for communication and Tubes for r.f. heating Types PE05/25 - TBW15/125	December 1975
Part 1b	Transmitting tubes for communication Tubes for r.f. heating Amplifier circuit assemblies	January 1976
Part 2	Microwave products Communication magnetrons Magnetrons for microwave heating Klystrons Travelling-wave tubes	May 1976
	Diodes Triodes T-R Switches Microwave semiconductor devices Isolators - circulators	
Part 3	Special Quality tubes; Miscellaneous devices	January 1975
Part 4	Receiving tubes	March 1975
Part 5a	Cathode-ray tubes	August 1976
Part 5b	Camera tubes; Image intensifier tubes	May 1975
Part 6	Products for nuclear technology Channel electron multipliers Geiger-Mueller tubes Neutron tubes	January 1977
Part 7	Gas-filled tubes Voltage stabilizing and reference tubes Counter, selector, and indicator tubes Trigger tubes Switching diodes	August 1975
	Thyratrons Ignitrons Industrial rectifying tubes High-voltage rectifying tubes	
Part 8	TV Picture tubes	October 1975
Part 9	Photomultiplier tubes Phototubes (diodes)	June 1976

SEMICONDUCTORS AND INTEGRATED CIRCUITS (RED SERIES)

This series consists of the following parts, issued on the dates indicated.

Part 1a	Rectifier diodes, thyristors, triacs		March 1976
	Rectifier diodes	Rectifier stacks	
	Voltage regulator diodes (> 1,5 W)	Thyristors	
	Transient suppressor diodes	Triacs	
Part 1b	Diodes		October 1975
	Small signal germanium diodes	Voltage regulator diodes (< 1,5 W)	
	Small signal silicon diodes	Voltage reference diodes	
	Special diodes	Tuner diodes	
Part 2	Low-frequency transistors		December 1975
Part 3	High-frequency and switching transistors		April 1976
Part 4a	Special semiconductors		June 1976
	Transmitting transistors	Dual transistors	
	Microwave devices	Microminiature devices for	
	Field-effect transistors	thick- and thin-film circuits	
Part 4b	Devices for optoelectronics		July 1976
	Photosensitive diodes and transistors	Photocouplers	
	Light emitting diodes	Infrared sensitive devices	
	Displays	Photoconductive devices	
Part 5a	Professional analogue integrated circuits		November 1976
	N.B. Consumer circuits will be issued in part 5b		
Part 6	Digital integrated circuits		May 1976
	LOCMOS HE family		
	GZ family		

COMPONENTS AND MATERIALS (GREEN SERIES)

This series consists of the following parts, issued on the dates indicated.

Part 1	Functional units, Input/output devices, Peripheral devices		November 1975
	High noise immunity logic FZ/30-Series Circuit blocks 40-Series and CSA70 Counter modules 50-Series NORbits 60-Series, 61-Series	Circuit blocks 90-Series Input/output devices Hybrid integrated circuits Peripheral devices	
Part 2a	Resistors		February 1976
	Fixed resistors Variable resistors Voltage dependent resistors (VDR) Light dependent resistors (LDR)	Negative temperature coefficient thermistors (NTC) Positive temperature coefficient thermistors (PTC) Test switches	
Part 2b	Capacitors		April 1976
	Electrolytic and solid capacitors Paper capacitors and film capacitors	Ceramic capacitors Variable capacitors	
Part 3	Radio, Audio, Television		February 1975
	FM tuners Loudspeakers Television tuners and aerial input assemblies	Components for black and white television Components for colour television	
Part 4a	Soft ferrites		October 1976
	Ferrites for radio, audio and television Beads and chokes	Ferroxcube potcores and square cores Ferroxcube transformer cores	
Part 4b	Piezoelectric ceramics, Permanent magnet materials		December 1976
Part 5	Ferrite core memory products		July 1975
	Ferroxcube memory cores Matrix planes and stacks	Core memory systems	
Part 6	Electric motors and accessories		September 1975
	Small synchronous motors Stepper motors	Miniature direct current motors	
Part 7	Circuit blocks		September 1971
	Circuit blocks 100 kHz-Series Circuit blocks 1-Series Circuit blocks 10-Series	Circuit blocks for ferrite core memory drive	
Part 8	Variable mains transformers		July 1975
Part 9	Piezoelectric quartz devices		March 1976
Part 10	Connectors		November 1975

Channel electron multipliers



GENERAL EXPLANATORY NOTES CHANNEL ELECTRON MULTIPLIERS

DESCRIPTION

A channel electron multiplier is a small curved glass tube, the inside wall of which is coated with a resistive material. When a potential is applied between the ends of the tube the resistive surface forms a continuous dynode, analagous to the separate dynodes of a conventional photomultiplier together with its associated resistive chain.

An electron entering the negative potential end of the multiplier generates secondary electrons on collision with the wall of the tube. These are accelerated along the tube until they strike the wall again where they generate further secondary electrons. This avalanching process continues along the length of the tube producing a large pulse of electrons at the positive end of the tube.

The channel electron multiplier must operate in a vacuum. For space research, the environmental vacuum is sufficient but in the laboratory the multiplier must be used in a vacuum chamber.

DEFINITIONS

Gain

The output pulse corresponding to one input electron will show a statistical spread. Due to saturation effects in the multiplier this spread is approximately Gaussian and the gain is defined as its median value.

For a gain of $1,0 \times 10^8$ a single input electron will produce an output of 16 picocoulombs.

The gain is constant up to a count rate of 1000 pulses per second. Above this the gain falls by approximately 3 dB per octave. The count rate capability of the system may be increased by lowering the measuring threshold.

Background

The background pulse count rate is the number of pulses detected per second above the specified threshold and operating voltage when the input end of the multiplier is closed. There is no appreciable variation of background count rate when either the applied voltage or ambient temperature is changed.

Starting voltage

The starting voltage is the operating voltage at which 90% of the output pulses from single electron inputs exceed the specified threshold.



Resolution

The resolution of the multiplier is calculated from the pulse height distribution by taking the full width half maximum (F. W. H. M.) spread divided by its median value. This is expressed as a percentage.

Effective input aperture

The effective input aperture is defined as the boundary within which the count above the equivalent threshold remains greater than 50% of its maximum value.

MODE OF OPERATION

The multiplier is most commonly used with pulse counting circuits to detected individual particles of quanta. For this application closed end multipliers are recommended.

A typical circuit is shown in Figure 1. The output pulse is capacitively coupled into a suitable charge sensitive pulse amplifier and discriminator. Under certain circumstances the multiplier may be used as a current amplifier. In this case an openended multiplier is necessary, the output being collected at a separate electrode as shown in Figure 2.

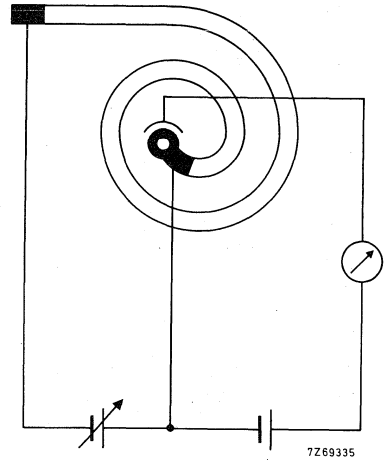
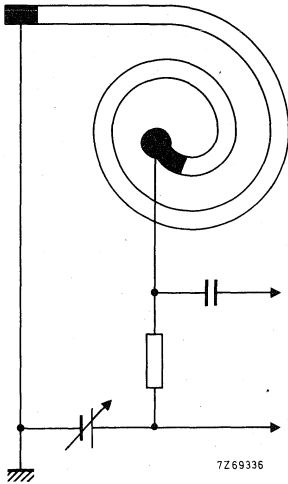

The collector electrode is biased positively to ensure collection of all output electrons. For satisfactory linearity the multiplier should be operated with a gain of less than 1×10^5 and the output current should not exceed 1% of the standing current.

OPERATIONAL NOTES

Mounting

It is recommended that, in general, the leads are not used for mounting the device as sustained vibration may result in fracture of the electrical connections.

Vacuum environment

Normal vacuum precautions should be observed. In particular gross contamination with hydrocarbon vapours will cause rapid loss of gain and should be avoided. If necessary the device may be cleaned in iso-propyl alcohol and air dried at a temperature not exceeding 70 °C.

The device is stable in air and may be vacuum cycled repeatedly without damage.

Baking conditions

The specified baking conditions apply when the device is under vacuum. The temperature must not exceed the specified maximum operating and storage temperature unless the pressure is less than 50 mN/m² (3,7 x 10⁻⁴ torr). No voltage should be applied to the device during bake-out.

Thermal stability

Due to negative temperature coefficient of resistance of the devices thermal runaway is possible. Operation below the maximum voltage and temperature limits specified will ensure that this does not occur.

Choice of operating voltage

Use of an operating voltage approximately 500 volts greater than the starting voltage will ensure that all output pulses exceed the threshold and are recorded. If, as a result of prolonged use the median gain of the multiplier falls, the operating voltage may be increased in order to restore the gain to its original value.



GENERAL EXPLANATORY NOTES

CHANNEL PLATES

PRINCIPLES OF OPERATION

Multi-channel plates depend on the same physical phenomenon as single channel electron multipliers. They comprise a plate of special glass through which pass a large number of channels. The walls of the holes are specially processed to coat them with a high resistance material which also has a coefficient of secondary emission greater than 1. If a potential is applied between opposite faces of the plate each channel becomes a continuous dynode analogous to the separate dynodes of a photomultiplier together with its resistive chain.

As with single channel multipliers, the channel plate operates in a vacuum. It is important that the vacuum should be better than 13,3 mPa (1×10^{-4} torr). An electron entering the low voltage end of one of the channels will generate secondary electrons on striking the wall. These in turn will be accelerated by the axial field and will again strike the wall, producing a further increase in the number of secondaries and so on. The avalanching process produces a large burst of electrons at the output end of the channel, corresponding to each input electron. As illustrated in Fig. 1 there is a statistical variation in pulse size depending on several factors. The channels are set at an angle to the face of the plate to ensure that electrons approaching the plate normally will not fail to strike the wall. The output contains about 10^3 electrons for each input electron. The gain is a steep function of applied voltage and the supply should be well regulated for stability of operation.

The multiplier is usually used to amplify the electrons emitted from a photocathode placed close to the input face, and excites a phosphor screen placed close to the output, preserving the spatial resolution and making an amplified image of the information on the photocathode. The input of the channel is also sensitive to ions, beta particles, X-rays, or any radiation of a suitable energy and this extends its use to many other applications. Since the resistive path is continuous, many electron paths are possible and the number of stages of amplification is indeterminate. The electron trajectories are scaled in proportion to the dimensions of the channel for a given applied voltage. Thus if the length to diameter ratio is kept constant the gain per channel remains constant, irrespective of the absolute length of the channel. For most applications the spatial resolution is important and in order to achieve the highest resolutions the channel diameters and the walls between channels are kept as small as possible.

GENERAL CHANNEL PLATES

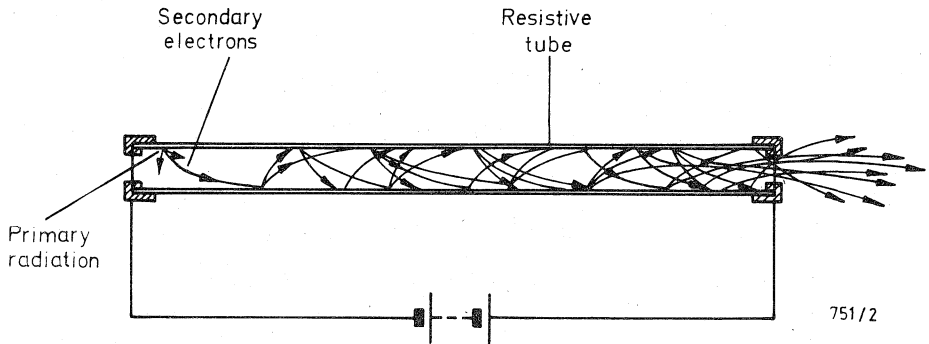

IONIC FEEDBACK

The electron cloud at the output of the plate is sufficiently intense to generate an appreciable number of ions and these drift towards the input of the channel and on striking the wall can produce a further burst of secondary electrons. This pulse, starting near the output, will be smaller than the first pulse, but may also generate ions which will drift backwards, so that a train of pulses is generated. This train of pulses alters the charge on the wall, which reduces the gain. This effect limits the voltage that can be applied to the plate and thus the gain that can be achieved. By placing two plates in cascade with the channels angled in opposite directions, ions fed back from the output plate cannot enter the input plate and high gain can be achieved without excessive ion feedback and consequent loss of linearity.

SATURATION DUE TO SPACE CHARGE

If the charge in the output pulse reaches about 10^8 electrons the gain cannot increase further. The space charge in the output end of the channel repels secondary electrons, causing them to return to the wall without generating further electrons. When this occurs with an imaging application it will cause poor highlights and loss of detail. Imaging plates usually operate at gains of around 10^3 .

SATURATION DUE TO FIELD DISTORTION

When the current in the output averages more than 10% of the total current, the voltage gradient in the wall is no longer linear and the gain falls so that there is a loss of linearity between input and output currents and a loss of highlights in the image.

SATURATION DUE TO FIELD EMISSION

It is important to keep channel plates scrupulously clean. Particles lodging in a channel can give rise to field emission which is multiplied in the channel and produces a permanently saturated condition. This is known as a switched on channel and is a condition extremely difficult to correct.

RESISTANCE

The resistance of a channel plate is the value measured in vacuum between electrodes applied to the input and output faces.

DARK CURRENT

Dark current is generally very low, much less than 1 count/s/cm² of plate area.

OPEN AREA

Open area is the total cross-section of all the channels in the plate expressed as a percentage of the total area of the plate.

GAIN

Gain in the linear region of operation is defined as the output current divided by the input current. This is always better than 1000 for 1000 volt applied to the plate and increases one order for each 200 V increase in applied voltage. The recommended operating voltage is 800 to 1200 V. Outside these limits spatial non-uniformity can become a problem.

MOUNTING

The opposite faces of channel plates are ground flat and parallel during manufacture. As the devices are fragile, care must be taken to ensure that they are not stressed unduly when mounting them in systems. It is recommended that they are placed between perfectly flat polished stainless steel rings spring loaded only sufficiently to ensure reliable connections to the metallized faces of the plate. A loading of 3 N per cm of periphery has been found adequate. Care must be taken to minimize the possibility of leakage or other currents between the contact rings when the working voltage is applied.

OPERATING TEMPERATURE AND OUTGASSING

The devices can be operated up to a maximum of 70 °C and degassed up to a maximum of 300 °C. Further evolution of gas may take place during operation. The pressure should never be allowed to rise above 13,3 mPa (1×10^{-4} torr) whilst the operating voltage is applied, but exposure to atmosphere for a few hours at a time does not cause any loss of performance. It is prudent to store devices in a well desiccated container if they have to be removed from the vacuum environment for longer periods. The devices may be damaged permanently if exposed to gross contamination by hydrocarbon vapours.

If the output is to be detected by means of a phosphor screen it is desirable to place it as close to the channel plate as can be arranged, commensurate with voltage and mechanical considerations. The electrons leave the outputs over a very wide angle, and detail can be lost if the spacing is excessive. For similar reasons a photocathode input source should be placed close to the input face.

A suitable distance for the channel plate/screen gap is 1 mm, with a potential between screen and channel plate output of about 5 kV. Either the screen distance or the screen potential may be adjusted in order to optimize the resolution of the system.

CHANNEL ELECTRON MULTIPLIER

Channel electron multiplier in the form of a glass planar spiral tube.

QUICK REFERENCE DATA			
The B310AL/01 has an open-ended output.			
The B310BL/01 has a closed output.			
Typical gain at 3.0 kV	1.3 x 10 ⁸		
Typical resistance	3.0 x 10 ⁹	Ω	
Maximum operating voltage	4.0	kV	

Unless otherwise stated, data is applicable to both types

This data should be read in conjunction with
GENERAL EXPLANATORY NOTES - CHANNEL ELECTRON MULTIPLIERS

CHARACTERISTICS (measured at 3.0 kV and 1000 pulse/s where applicable)

	Min.	Typ.	Max.	
Resistance	2.0	3.0	5.0	x 10 ⁹ Ω
Gain, see note 1)	1.0	1.3	-	x 10 ⁸
Background above an equivalent threshold of 2.0 x 10 ⁷ electrons	-	0.1	0.2	pulse/s
Starting voltage with an equivalent threshold of 2.0 x 10 ⁷ electrons	2.0	2.5	2.6	kV
Resolution (F.W.H.M.) at a modal gain of 1.0 x 10 ⁸	-	50	70	%
Effective input diameter	1.1	1.25	-	mm

LIMITING VALUES (Absolute max. rating system)

Operating voltage	max.	4.0	kV
Temperature, operating and storage	max.	70	°C
Bake temperatures, see note 2)	max.	400	°C
Ambient pressure with high voltage applied	max.	50 3.7 x 10 ⁻⁴	mN/m ² torr



MASS

1.0

g

MOUNTING POSITION

Any. In environments where vibration may be encountered the device should not be supported by the leads alone.

NOTES

- 1) The gain of a typical multiplier will increase by a factor of 2 for an increase of operating voltage of 500 V.
- 2) Baking will cause a permanent slight loss in gain and it is advisable to keep the baking time to a minimum, for example, baking for 16 hours at 400 °C will reduce gain by approximately a factor of 2.

DIMENSIONS AND CONNECTIONS

Dimensions in mm

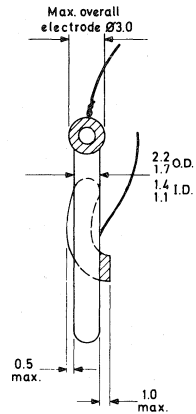
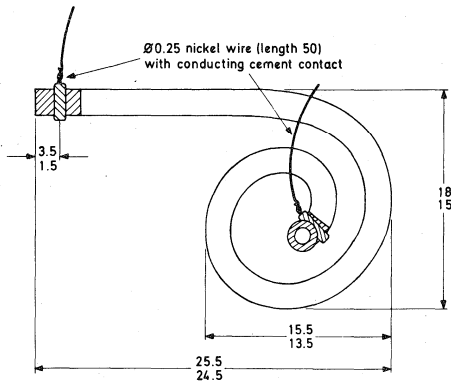

7260869

CHANNEL ELECTRON MULTIPLIER

Channel electron multiplier in the form of a glass planar spiral tube with a rectangular-section input cone 2.0 x 8.0 mm.

QUICK REFERENCE DATA

The B312AL/01 has an open-ended output.

The B312BL/01 has a closed output.

Typical gain at 3.0 kV	1.3 x 10 ⁸	
Typical resistance	3.0 x 10 ⁹	Ω
Maximum operating voltage	4.0	kV

Unless otherwise stated, data is applicable to both types

This data should be read in conjunction with
GENERAL EXPLANATORY NOTES - CHANNEL ELECTRON MULTIPLIERS

CHARACTERISTICS (measured at 3.0 kV and 1000 pulse/s where applicable)

	Min.	Typ.	Max.	
Resistance	2.0	3.0	5.0 x 10 ⁹	Ω
Gain, see note 1)	1.0	1.3	-	x 10 ⁸
Background above an equivalent threshold of 2.0 x 10 ⁷ electrons	-	0.2	0.5	pulse/s
Starting voltage with an equivalent threshold of 2.0 x 10 ⁷ electrons	2.0	2.5	2.6	kV
Resolution (F. W. H. M.) at a modal gain of 1.0 x 10 ⁸	-	50	70	%
Effective input aperture	1.7 x 7.5	2.0 x 8.0	-	mm

LIMITING VALUES (Absolute max. rating system)

Operating voltage	max.	4.0	kV
Temperature, operating and storage	max.	70	°C
Bake temperatures, see note 2)	max.	400	°C
Ambient pressure with high voltage applied	max.	50	mN/m ²
		3.7 x 10 ⁻⁴	torr

MASS

1.0

g

MOUNTING POSITION

Any. In environments where vibration may be encountered the device should not be supported by the leads alone.

NOTES

- 1) The gain of a typical multiplier will increase by a factor of 2 for an increase of operating voltage of 500 V.
- 2) Baking will cause a permanent slight loss in gain and it is advisable to keep the baking time to a minimum, for example, baking for 16 hours at 400 °C will reduce gain by approximately a factor of 2.

DIMENSIONS AND CONNECTIONS

Dimensions in mm

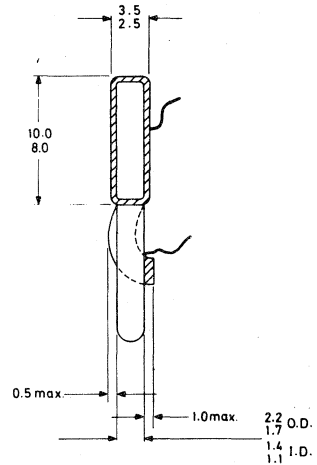
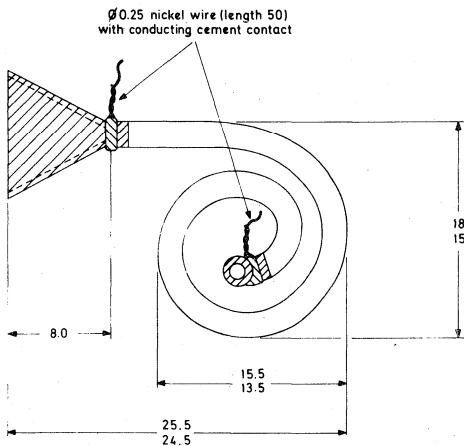

7260870

CHANNEL ELECTRON MULTIPLIER

Channel electron multiplier in the form of a glass planar spiral tube with a 5.0 mm diameter input cone.

QUICK REFERENCE DATA

The B318AL/01 has an open-ended output.

The B318BL/01 has a closed output.

Typical gain at 3.0 kV	1.3 x 10 ⁸	
Typical resistance	3.0 x 10 ⁹	Ω
Maximum operating voltage	4.0	kV

Unless otherwise stated, data is applicable to both types

This data should be read in conjunction with
GENERAL EXPLANATORY NOTES - CHANNEL ELECTRON MULTIPLIERS

CHARACTERISTICS (measured at 3.0 kV and 1000 pulse/s where applicable)

	Min.	Typ.	Max.	
Resistance	2.0	3.0	5.0	x 10 ⁹ Ω
Gain, see note 1)	1.0	1.3	-	x 10 ⁸
Background above an equivalent threshold of 2.0 x 10 ⁷ electrons	-	0.25	0.5	pulse/s
Starting voltage with equivalent threshold of 2.0 x 10 ⁷ electrons	2.0	2.5	2.6	kV
Resolution (F. W. H. M.) at a modal gain 1.0 x 10 ⁸	-	50	70	%
Effective cone diameter	4.0	5.0	-	mm

LIMITING VALUES (Absolute max. rating system)

Operating voltage	max.	4.0	kV
Temperature, operating and storage	max.	70	°C
Bake temperatures, see note 2)	max.	400	°C
Ambient pressure with high voltage applied	max.	50 3.7 x 10 ⁻⁴	mN/m ² torr

MASS

1.3

g

MOUNTING POSITION

Any. In environments where vibration may be encountered the device should not be supported by the leads alone.

NOTES

- 1) The gain of a typical multiplier will increase by a factor of 2 for an increase of operating voltage of 500 V.
- 2) Baking will cause a permanent slight loss in gain and it is advisable to keep the baking time to a minimum, for example, baking for 16 hours at 400 °C will reduce gain by approximately a factor of 2.

DIMENSIONS AND CONNECTIONS

Dimensions in mm

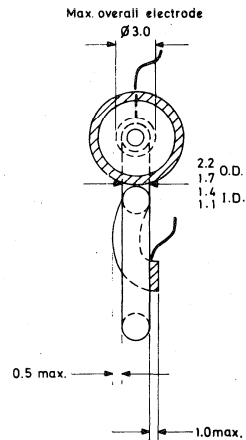
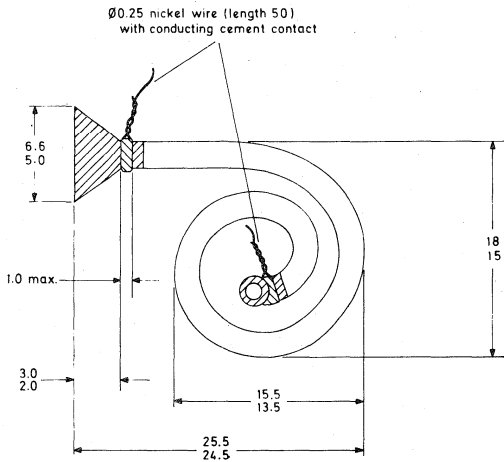

7260871

CHANNEL ELECTRON MULTIPLIER

Channel electron multiplier in the form of a glass C-shaped tube.

QUICK REFERENCE DATA		
The B330AL/01 has an open-ended output.		
The B330BL/01 has a closed output.		
Typical gain at 3.0 kV	1.5×10^8	
Typical resistance	3.0×10^9	Ω
Maximum operating voltage	4.0	kV

Unless otherwise stated, data is applicable to both types

This data should be read in conjunction with
GENERAL EXPLANATORY NOTES - CHANNEL ELECTRON MULTIPLIERS

CHARACTERISTICS (measured at 3.0 kV and 1000 pulse/s where applicable)

	Min.	Typ.	Max.	
Resistance	2.0	3.0	5.0	$\times 10^9 \Omega$
Gain, see note 1)	1.0	1.5	-	$\times 10^8$
Background above an equivalent threshold of 2.0×10^7 electrons	-	0.1	0.2	pulse/s
Starting voltage with an equivalent threshold of 2.0×10^7 electrons	2.0	2.5	2.6	kV
Resolution (F. W. H. M.) at a modal gain of 1.0×10^8	-	50	70	%
Effective input diameter	1.1	1.25	-	mm

LIMITING VALUES (Absolute max. rating system)

Operating voltage	max.	4.0		kV
Temperature, operating and storage	max.	70		$^{\circ}\text{C}$
Bake temperatures, see note 2)	max.	400		$^{\circ}\text{C}$
Ambient pressure with high voltage applied	max.	50		mN/m^2
		3.7×10^{-4}		torr



MASS

1,3

g

MOUNTING POSITION

Any. In environments where vibration may be encountered the device should not be supported by the leads alone.

NOTES

- 1) The gain of a typical multiplier will increase by a factor of 2 for an increase of operating voltage of 500 V.
- 2) Baking will cause a permanent slight loss in gain and it is advisable to keep the baking time to a minimum, for example, baking for 16 hours at 400 °C will reduce gain by approximately a factor of 2.

DIMENSIONS AND CONNECTIONS

Dimensions in mm

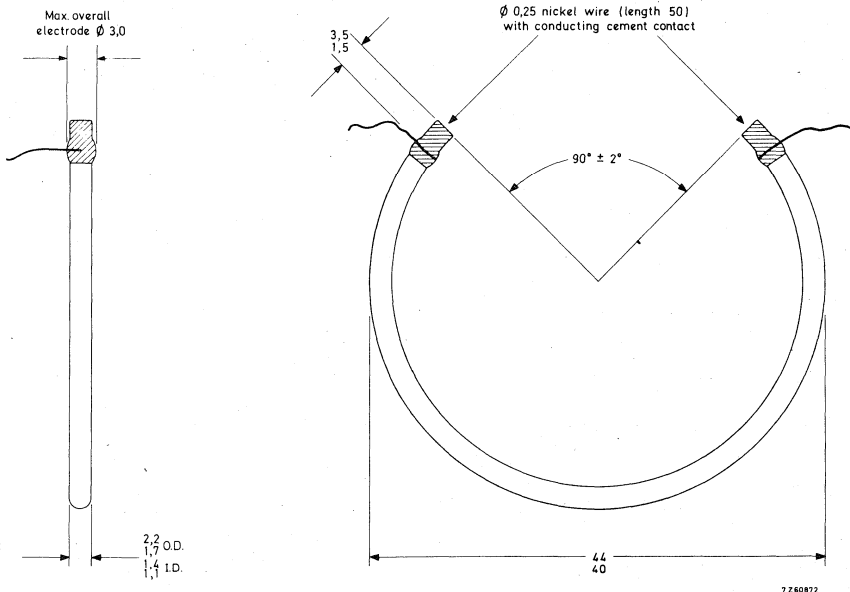

CHANNEL ELECTRON MULTIPLIER

Channel electron multiplier in the form of a glass planar spiral tube.

QUICK REFERENCE DATA			
The B410AL/01 has an open-ended output.			
The B410BL/01 has a closed output.			
Typical gain at 2.5 kV	1.5 x 10 ⁸		
Typical resistance	3.0 x 10 ⁹	Ω	
Maximum operating voltage	3.5	kV	

Unless otherwise stated, data is applicable to both types

This data should be read in conjunction with
GENERAL EXPLANATORY NOTES - CHANNEL ELECTRON MULTIPLIERS

CHARACTERISTICS (measured at 2.5 kV and 1000 pulse/s where applicable)

	Min.	Typ.	Max.	
Resistance	2.0	3.0	5.0	x 10 ⁹ Ω
Gain, see note 1)	1.0	1.5	-	x 10 ⁸
Background above an equivalent threshold of 2.0 x 10 ⁷ electrons	-	0.1	0.2	pulse/s
Starting voltage with an equivalent threshold of 2.0 x 10 ⁷ electrons	1.7	2.0	2.2	kV
Resolution (F. W. H. M.) at a modal gain of 1.0 x 10 ⁸	-	50	70	%
Effective input diameter	2.0	2.2	-	mm

LIMITING VALUES (Absolute max. rating system)

Operating voltage	max.	3.5	kV
Temperature, operating and storage	max.	70	°C
Bake temperatures, see note 2)	max.	400	°C
Ambient pressure with high voltage applied	max.	50 3.7 x 10 ⁻⁴	mN/m ² torr

MASS

3.0

g

MOUNTING POSITION

Any. In environments where vibration may be encountered the device should not be supported by the leads alone.

NOTES

- 1) The gain of a typical multiplier will increase by a factor of 2 for an increase of operating voltage of 500 V.
- 2) Baking will cause a permanent slight loss in gain and it is advisable to keep the baking time to a minimum, for example, baking for 16 hours at 400 °C will reduce gain by approximately a factor of 2.

DIMENSIONS AND CONNECTIONS

Dimensions in mm

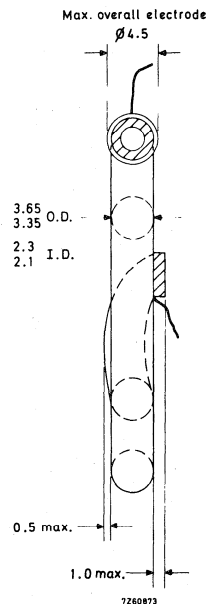
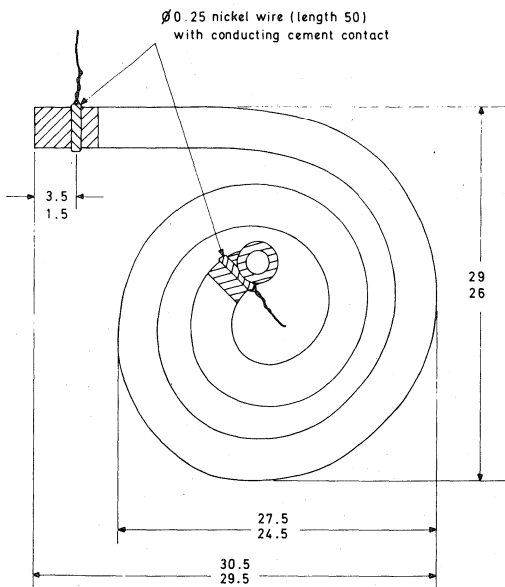

CHANNEL ELECTRON MULTIPLIER

Channel electron multiplier in the form of a glass planar spiral tube with a rectangular-section input cone 3.5 x 15.5 mm.

QUICK REFERENCE DATA

The B413AL/01 has an open-ended output

The B413BL/01 has a closed output

Typical gain at 2.5 kV	1.7 x 10 ⁸	
Typical resistance	3.0 x 10 ⁹	Ω
Maximum operating voltage	3.5	kV

Unless otherwise stated, data is applicable to both types

This data should be read in conjunction with
GENERAL EXPLANATORY NOTES - CHANNEL ELECTRON MULTIPLIERS

CHARACTERISTICS (measured at 2.5 kV and 1000 pulse/s where applicable)

	Min.	Typ.	Max.	
Resistance	2.0	3.0	5.0	x 10 ⁹ Ω
Gain, see note 1)	1.0	1.7	-	x 10 ⁸
Background above an equivalent threshold of 2.0 x 10 ⁷ electrons	-	0.25	0.5	pulse/s
Starting voltage with an equivalent threshold of 2.0 x 10 ⁷ electrons	1.7	2.0	2.2	kV
Resolution (F.W.H.M.) at a modal gain of 1.0 x 10 ⁸	-	50	70	%
Effective input aperture	3.0 x 14.5	3.5 x 15.5	-	mm

LIMITING VALUES (Absolute max. rating system)

Operating voltage	max.	3.5	kV
Temperature, operating and storage	max.	70	°C
Bake temperature, see note 2)	max.	400	°C
Ambient pressure with high voltage applied	max.	50	mN/m ² 3.7 x 10 ⁻⁴ torr

MASS

4.0

g

MOUNTING POSITION

Any. In environments where vibration may be encountered the device should not be supported by the leads alone.

NOTES

- 1) The gain of a typical multiplier will increase by a factor of 2 for an increase of operating voltage of 500 V.
- 2) Baking will cause a permanent slight loss in gain and it is advisable to keep the baking time to a minimum, for example, baking for 16 hours at 400 °C will reduce gain by approximately a factor of 2.

DIMENSIONS AND CONNECTIONS

Dimensions in mm

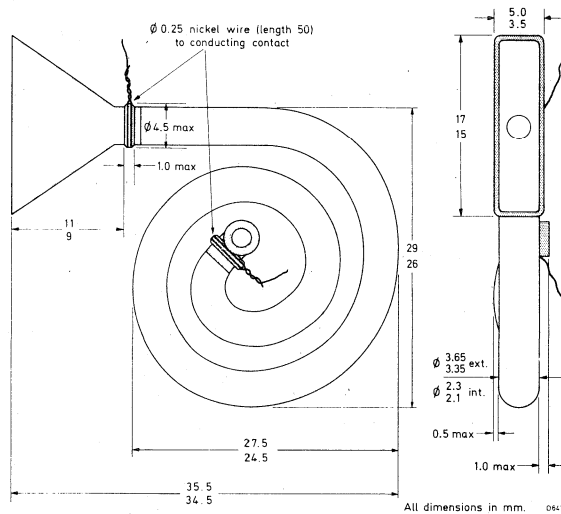

CHANNEL ELECTRON MULTIPLIER

Channel electron multiplier in the form of a glass planar spiral tube with a 10 mm diameter input cone.

QUICK REFERENCE DATA

The B419AL/01 has an open-ended output.

The B419BL/01 has a closed output.

Typical gain at 2.5 kV	1.7 x 10 ⁸	
Typical resistance	3.0 x 10 ⁹	Ω
Maximum operating voltage	3.5	kV

Unless otherwise stated, data is applicable to both types

This data should be read in conjunction with
GENERAL EXPLANATORY NOTES - CHANNEL ELECTRON MULTIPLIERS

CHARACTERISTICS (measured at 2.5 kV and 1000 pulse/s where applicable)

	Min.	Typ.	Max.	
Resistance	2.0	3.0	5.0	x 10 ⁹ Ω
Gain, see note 1)	1.0	1.7	-	x 10 ⁸
Background above an equivalent threshold of 2.0 x 10 ⁷ electrons	-	0.25	0.5	pulse/s
Starting voltage with an equivalent threshold of 2.0 x 10 ⁷ electrons	1.7	2.0	2.2	kV
Resolution (F. W. H. M.) at a modal gain of 1.0 x 10 ⁸	-	50	70	%
Effective input diameter	9.0	10.0	-	mm

LIMITING VALUES (Absolute max. rating system)

Operating voltage	max.	3.5	kV
Temperature, operating and storage	max.	70	°C
Bake temperatures, see note 2)	max.	400	°C
Ambient pressure with high voltage applied	max.	50 3.7 x 10 ⁻⁴	mN/m ² torr

MASS

4.0

g

MOUNTING POSITION

Any. In environments where vibration may be encountered the device should not be supported by the leads alone.

NOTES

- 1) The gain of a typical multiplier will increase by a factor of 2 for an increase of operating voltage of 500 V.
- 2) Baking will cause a permanent slight loss in gain and it is advisable to keep the baking time to a minimum, for example, baking for 16 hours at 400 °C will reduce gain by approximately a factor of 2.

DIMENSIONS AND CONNECTIONS

Dimensions in mm

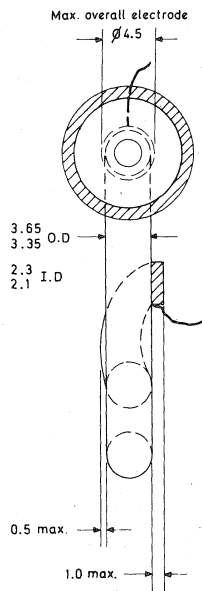
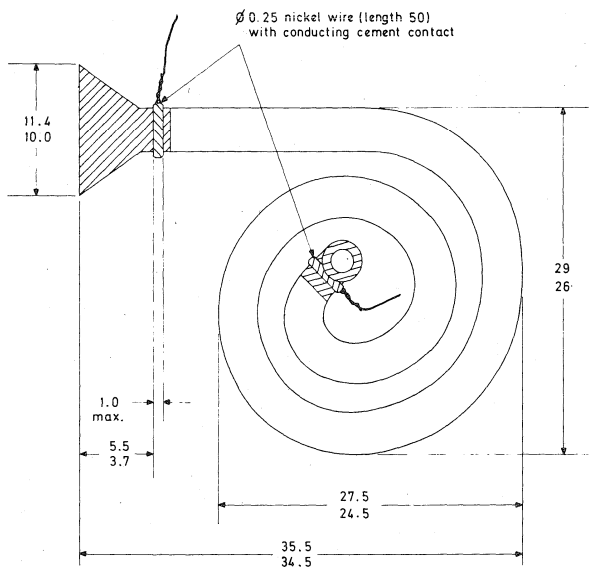

7260874

CHANNEL ELECTRON MULTIPLIER PLATE

An array of channel electron multipliers fused into the shape of a disc. The multipliers are electrically connected in parallel by means of nickel-chromium electrodes evaporated on to the faces of the disc.

SPECIFICATION

Diameter of disc		27,1 ± 0,1	mm
Useful diameter	min.	26,5	mm
Thickness of disc		1,0 ± 0,1	mm
Channel diameter		25	µm
Channel pitch		31	µm
Open area	approx.	60	%
Electrode material		nickel-chromium	
Electrical resistance between electrodes	approx.	50	MΩ
Current gain at 1 kV	min.	1000	

For linear relationship between input and output the output current must not exceed 0,1 of the standing current.

The plates are cut such that the channel electron multipliers form an angle of 13° to the perpendicular axis of the plate.

APPLICATIONS

These devices must operate in a vacuum, and may be used to detect electrons, ions, soft X-rays and ultra-violet photons falling on the input face of the disc, by producing electron pulses from the output face of the corresponding channel.

For space experiments the environmental vacuum is adequate for their operation.

In laboratory use they must be incorporated in a vacuum chamber, where they will have important applications in field ion microscopy, electron microscopy and allied areas of work.

Data based on pre-production devices

LIMITING VALUES (Absolute max. rating system)

Operating voltage	max.	2	kV
Temperature, operating and storage ¹⁾	max.	70	°C
Bake temperature	max.	300	°C
Ambient pressure with high voltage applied	max.	13,3	mPa (10 ⁻⁴ torr)
Diameter of plate clamping rings	max.	26,6	mm



¹⁾ The plate should be stored in a dry or vacuum environment.

CHANNEL ELECTRON MULTIPLIER PLATE

An array of channel electron multipliers fused into the shape of a disc. The multipliers are electrically connected in parallel by means of nickel-chromium electrodes evaporated on to the faces of the disc.

SPECIFICATION

Diameter of disc		53,0 ⁺⁰ -0,2	mm
Useful diameter	min.	51,8	mm
Thickness of disc		1,0 ± 0,1	mm
Channel diameter		25	µm
Channel pitch		31	µm
Open area	approx.	60	%
Electrode material		nickel-chromium	
Electrical resistance between electrodes	approx.	10	MΩ
Current gain at 1 kV	min.	1000	



For linear relationship between input and output the output current must not exceed 0,1 of the standing current.

The plates are cut such that the channel electron multipliers form an angle of 13° to the perpendicular axis of the plate.

APPLICATIONS

These devices must operate in a vacuum, and may be used to detect electrons, ions, soft X-rays and ultra-violet photons falling on the input face of the disc, by producing electron pulses from the output face of the corresponding channel.

For space experiments the environmental vacuum is adequate for their operation.

In laboratory use they must be incorporated in a vacuum chamber, where they will have important applications in field ion microscopy, electron microscopy and allied areas of work.

Data based on pre-production devices.

LIMITING VALUES (Absolute max. rating system)

Operating voltage	max.	2	kV
Temperature, operating and storage ¹⁾	max.	70	°C
Bake temperature	max.	300	°C
Ambient pressure with high voltage applied	max.	13,3	mPa (10 ⁻⁴ torr)
Diameter of plate clamping rings	max.	52,4	mm

¹⁾ The plate should be stored in a dry or vacuum environment.

CHANNEL ELECTRON MULTIPLIER PLATE

An array of channel electron multipliers fused into the shape of a disc. The multipliers are electrically connected in parallel by means of nickel-chromium electrodes evaporated on to the faces of the disc.

SPECIFICATION

Diameter of disc		70,0	⁺⁰ _{-0,2}	mm
Useful diameter	min.	68		mm
Thickness of disc		1,0	$\pm 0,1$	mm
Channel diameter		25		μm
Channel pitch		31		μm
Open area	approx.	60		%
Electrode material		nickel-chromium		
Electrical resistance between electrodes	approx.	5		M Ω
Current gain at 1 kV	min.	1000		

For linear relationship between input and output the output current must not exceed 0,1 of the standing current.

The plates are cut such that the channel electron multipliers form an angle of 13° to the perpendicular axis of the plate.

APPLICATIONS

These devices must operate in a vacuum, and may be used to detect electrons, ions, soft X-rays and ultra-violet photons falling on the input face of the disc, by producing electron pulses from the output face of the corresponding channel.

For space experiments the environmental vacuum is adequate for their operation.

In laboratory use they must be incorporated in a vacuum chamber, where they will have important applications in field ion microscopy, electron microscopy and allied areas of work.

Data based on pre-production devices.

LIMITING VALUES (Absolute max. rating system)

Operating voltage	max.	2	kV
Temperature, operating and storage ¹⁾	max.	70	°C
Bake temperature	max.	300	°C
Ambient pressure with high voltage applied	max.	13,3	mPa (10 ⁻⁴ torr)
Diameter of plate clamping rings	max.	68,5	mm

¹⁾ The plate should be stored in a dry or vacuum environment.

Geiger-Mueller tubes



**GEIGER-MÜLLER TUBES
SURVEY OF TYPES**

Type number	Replaces Philips	Replaces Mullard	Status	Application
Cylinder types				γ
ZP1200	18503	MX146	C	γ 10^{-4} to 1 R/h
ZP1210	18520	MX120/01	D	γ 4×10^{-4} to 2×10^{-1} R/h
ZP1220	18545	MX145	D	γ 10^{-4} to 10^{-1} R/h
Cylinder types				β, γ
ZP1300	18529	MX163	D	β, γ 10^{-2} to 2×10^3 R/h
ZP1310	18509	MX150	D	β, γ 10^{-3} to 3×10^2 R/h
ZP1311	ZP1100	MX189	D	β, γ 10^{-3} to 3×10^2 R/h
ZP1320	18550	MX164	D	β, γ 10^{-3} to 10^2 R/h
ZP1330	18555	MX177	D	β, γ 10^{-3} to 10 R/h
Window types				α, β, γ (or combinations)
ZP1400	18504	MX147	D	β, γ 10^{-4} to 1 R/h
ZP1410	18505	MX148	D	α, β, γ 10^{-4} to 3 R/h
ZP1430	18526	MX169	D	α, β, γ 10^{-4} to 2 R/h
ZP1440	18515/01	MX152/01	D	α, β 10^{-2} to 10 R/h
ZP1441	18515	MX152	M	α, β 10^{-2} to 10 R/h
ZP1450	18536/01	MX166/01	D	α, β 10^{-4} to 3 R/h
ZP1451	18536	MX166	M	α, β 10^{-4} to 3 R/h
ZP1460	18546/01	MX167/01	D	β 3×10^{-5} to 10^{-1} R/h
Liquid types				β, γ
ZP1500	ZP1083	MX193	D	β, γ 3×10^{-4} to 1 R/h
ZP1501	ZP1080	MX194	C	β, γ 3×10^{-4} to 1 R/h
ZP1520	18525	MX124/01	D	β, γ
X-ray types				X-rays
ZP1600	18507	MX159	D	2, 5 to 20 keV
ZP1610	18511	MX161	D	2, 5 to 40 keV
Special types				
ZP1700	18518	MX155	M	cosmic-ray guard tube

- D = Design type Recommended for new equipment design.
- C = Current type Available for equipment production and maintenance.
No longer recommended for equipment design.
- M = Maintenance type Available for equipment maintenance.
No longer recommended for equipment production.

Some devices are labelled

Maintenance type

Obsolescent type

or

Obsolete type

Maintenance type - Available for equipment maintenance
No longer recommended for equipment production.

Obsolescent type - Available until present stocks are exhausted.

Obsolete type - No longer available.

GEIGER-MUELLER TUBES

LIST OF SYMBOLS

Anode supply voltage	V_b
Voltage at the beginning of the plateau	V_{b_1}
Voltage at the end of the plateau	V_{b_2}
Plateau length ($= V_{b_2} - V_{b_1}$)	V_{pl}
Starting voltage	V_{ign}
Count rate (= counts/unit of time)	N
Count rate at V_{b_1}	N_1
Count rate at V_{b_2}	N_2
Background	N_o
Plateau slope ($= \frac{N_2 - N_1}{0.5(N_1 + N_2)} \times \frac{1}{V_{pl}} \times 100\%$)	S_{pl}
Dead time	τ
Capacitance (anode to cathode)	C_{ak}
Ambient temperature	t_{amb}
Gas multiplication factor	A

GENERAL OPERATIONAL RECOMMENDATIONS GEIGER-MUELLER TUBES

1. GENERAL

- 1.1 A Geiger-Mueller tube (GM tube) is a gas-filled device which reacts to individual ionizing events, thus enabling them to be counted.
- 1.2 A Geiger-Mueller tube basically consists of an electrode at a positive potential (anode) surrounded by a metal cylinder at a negative potential (cathode). The cathode forms part of the envelope or is enclosed in a glass envelope. Quanta or particles may enter the tube either through a foil (the window), or through the cylinder wall itself.
- 1.3 Typical radiations are :
 - alpha;
 - beta;
 - gamma or X-ray ;
 - thermal neutrons.
- 1.4 The gas filling normally consists of a mixture of rare gases and a quenching agent.
- 1.5 Quenching is the process of terminating a pulse of ionization current in a counter tube.

2. CAPACITANCE

The capacitance of a GM tube is the capacitance between anode and cathode, the connections being completely shielded.

3. OPERATING CHARACTERISTICS

- 3.1 **Starting voltage** This is the minimum anode supply voltage applied to a GM tube at which pulses of 1 V amplitude appear across the tube.
- 3.2 **Operating voltage** This is the anode supply voltage at which the GM tube should be used.
If this is not quoted, the middle of the minimum plateau (i. e. $\frac{V_{b1} + V_{b2}}{2}$) should be regarded as the recommended operating voltage.
- 3.3 **Plateau** The range of anode supply voltage values for which the count rate varies relatively little under constant conditions of irradiation. Unless otherwise stated, the plateau is measured at a count rate of approximately 100 c/s.
- 3.4 **Plateau slope** The percentage change in count rate for a given change (usually 1 V) in anode supply voltage.
- 3.5 **Background** The count rate of a GM tube in the absence of radiation which the tube is meant to measure.

3.6 **Dead time** This is the time interval after the initiation of a voltage pulse during which (assuming no interference by an external circuit) a subsequent ionizing event does not produce a discharge.

Unless otherwise stated the dead time is given at a count rate of 100 c/s.

MEASURING CIRCUITS

4.1 Measuring circuit A

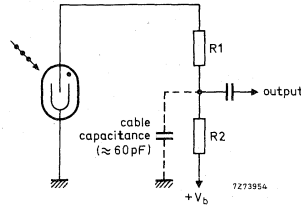

Note: The value of R1 should not be lower than specified under "Limiting values".
The resistor should be mounted as close as possible to the anode terminal.

4.2 Measuring circuit B

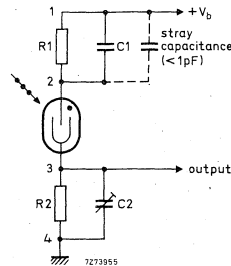

Notes

1. The input resistance and the input capacitance of the measuring equipment are incorporated in R_2 and C_2 , respectively.
2. The value of R_1 should be as specified by the manufacturer.
The resistor should be mounted as close as possible to the anode terminal.
3. When applying a rectangular pulse at 1, with the tube inserted but short-circuited, capacitor C_2 should be so adjusted that the pulse at 3 is undistorted.
Under these conditions $R_1 \cdot (C_1 + \text{stray capacitance}) = R_2 \cdot C_2$.
4. The measuring equipment consists of a cathode follower with a pulse shaper, a

limiting amplifier and a scaler.

Unless otherwise stated, the tubes are measured with the measuring circuit given in the data sheet and with a ^{60}Co source at

$$V_b = \frac{V_{b1} + V_{b2}}{2} \quad \text{and at } t_{\text{amb}} = 25 \text{ }^\circ\text{C}.$$

5. OPERATIONAL NOTES

- 5.1 **Pulse amplitude** The pulse amplitude of the GM tubes may be estimated generally at $P = b \cdot (V_b - V_{\text{ign}})$. In this formula V_b is the anode supply voltage and V_{ign} the starting voltage of the tube. The factor b originates from the tap on the anode resistor, as indicated in the recommended measuring circuit. The influence of the connected capacitive load is thus minimized.
- 5.2 **Scaler** The resolving time of the scaler should be shorter than the minimum dead time of the counter tube. For normal use and at moderate count rates an input sensitivity of approximately 0,25V will be sufficient. At very high count rates the mean level of the anode voltage of the counter tube will drop appreciably below V_b , and the pulse amplitude will decrease accordingly so that the smallest pulses will be lost at the input of the scaler. In this case it is possible to increase the sensitivity of the measuring equipment by means of a pulse amplifier combined with a pulse shaper.
- 5.3 **Pulse shaper and amplifier** The circuit should have a resolving time shorter than the minimum deadtime of the counter tube. The pulse amplitude should not be influenced by the pulse shaper. Pulse amplification should be sufficiently high and the rise time of the amplifier should be considerably smaller than the rise time of the pulse from the counter tube.
- 5.4 **Load** Normally the tubes should be operated with an anode resistor having a value as indicated in the data sheets or higher. Decreasing the resistance of the anode resistor not only decreases the dead time, but also the plateau length. A decrease in resistance below the indicated minimum value may affect tube life and even lead to its early destruction. The anode resistor should be connected direct to the anode connector (terminal) of the tube to ensure that parasitic capacitances of leads will not considerably increase the capacitive load on the tube. An increase in capacitive load has the tendency of increasing the pulse amplitude, the pulse duration, the dead time, and the plateau slope, whereas the plateau length will be shortened appreciably. Shunt capacitances of 20 pF or more may destroy the tube.
- 5.5 **Count rate** After every pulse the tube is temporarily insensitive during a period called dead time. Consequently, the pulses that occur during this period are not counted. At a count rate of N c/s the tube will be insensitive during $100 N \tau$ % of the time, so that approximately $100 N \tau$ % of the counts will be lost. If the counting losses should not exceed 1%, N should be less than $0,01 \tau$ c/s. The maximum count rate is approximately $1/\tau$. For continuous stable operation it is recommended that the count rate be adjusted to a value in the linear part of the count rate/dose rate curve.
- 5.6 **Count rate/dose rate curves** are measured with ^{60}Co perpendicular to the tube axis, at an operating voltage in the middle of the plateau, unless otherwise stated. The curves shown are typical curves. Deviations up to approximately $\pm 10\%$ may occur.

- 5.7 Current/dose rate curves are measured with ^{60}Co perpendicular to the tube axis, unless otherwise stated.
The curves shown are typical curves. Deviations up to approximately $\pm 10\%$ may occur.

6 LIMITING VALUES

- 6.1 The limiting values of radiation counter tubes are given in the absolute maximum rating system in accordance with IEC Publication 134.

Absolute maximum ratings are limiting values of operating and environmental conditions applicable to any electronic device of a specified type as defined by its published data, which should not be exceeded under the worst probable conditions.

These values are chosen by the device manufacturer to provide acceptable serviceability of the device, taking no responsibility for equipment variations, environmental variations, and the effects of changes in operating conditions due to variations in the characteristics of the device under consideration and of all other electronic devices in the equipment.

The equipment manufacturer should design so that, initially and throughout life, no absolute maximum value for the intended service is exceeded with any device under the worst probable operating conditions with respect to supply voltage variation, equipment component variation, equipment control adjustment, load variations, signal variation, environmental conditions, and variations in characteristics of the device under consideration and of all other electronic devices in the equipment.

- 6.2 The ambient temperature is the temperature of the surroundings of the tube.

7 MOUNTING

- 7.1 Unless otherwise stated, any mounting position is permissible.
- 7.2 Low capacitance mounting of the tube is required (**shortest possible** connection between anode terminal and load resistor; low capacitance between anode and cathode leads).
- 7.3 Soldering to the cathode can or the anode pin will **destroy** the tube.
Tubes with anode pin are supplied with an anode connector (see drawing).
Only this connector should be used for connecting the anode.

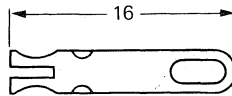

7Z75123

8 STORAGE AND HANDLING

- 8.1 The tube should not be stored at ambient temperatures outside the limits given under the heading "Limiting values" on the data sheets.
- 8.2 To prevent leakage between anode and cathode the tube should be dry and clean.
- 8.3 Condensation of water vapour may cause a short circuit between anode and cathode.

8.4 Some types of tube have thin windows and/or cathode walls.

To prevent damage, these tubes should be handled and mounted with utmost care. The mica-window types are provided with a cap to protect the window when not in operation.

9. OUTSIDE PRESSURE

9.1 Tubes provided with a window should not be subjected to an outside pressure lower than 33,3 kPa (33,3 mbar, \approx 25 cm Hg) or higher than the normal atmospheric pressure (unless otherwise stated).

Variations in pressure should be gradual.

9.2 Do not expose tubes with very thin envelopes to pressures substantially higher than normal atmospheric.

Never:

1. Exceed the "Limiting values".
2. Solder to the tube.
3. Bend the anode pin.
4. Touch the mica window.



BETA ABSORPTION IN TUBE WINDOW (APPROXIMATE VALUES IN %)

7Z76021

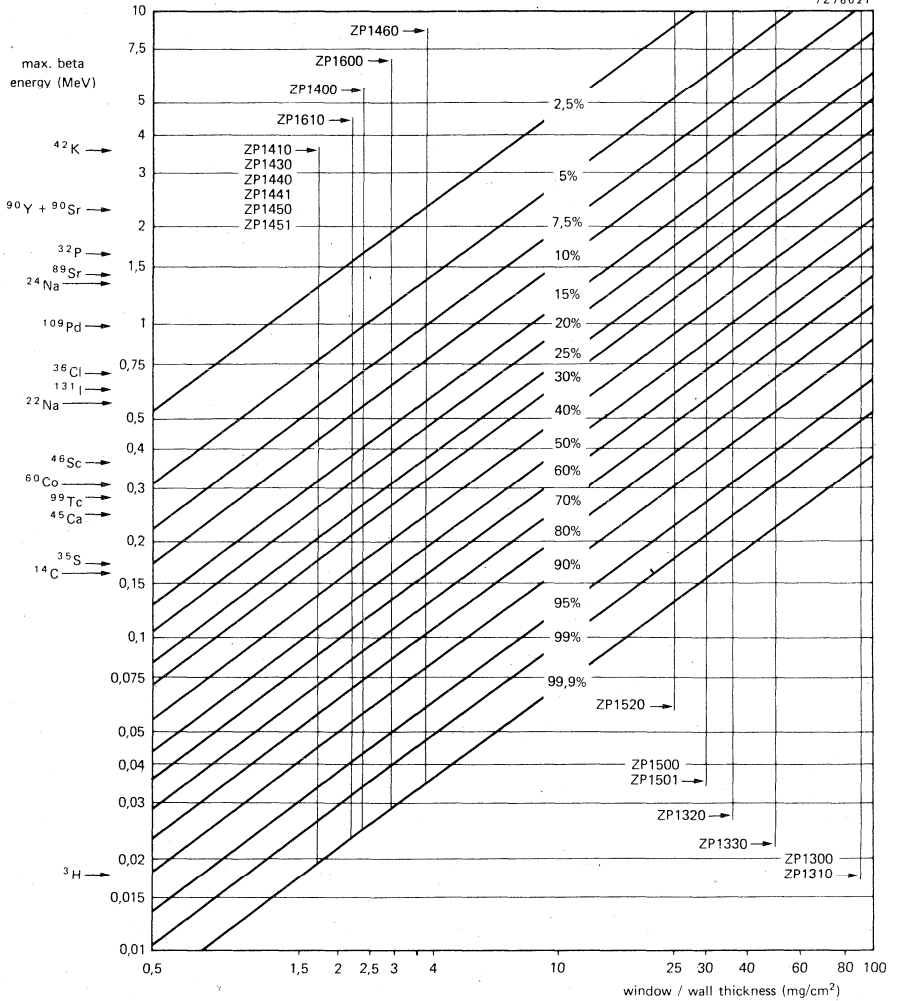

BETA ABSORPTION IN TUBE WALL (APPROXIMATE VALUES IN %)

GEIGER-MÜLLER TUBE

Glass-wall halogen quenched beta and gamma radiation dip-counter tube with a DIN base.
Replacement type ZP1511.



GEIGER-MÜLLER TUBE

Glass-wall halogen quenched beta and gamma radiation dip-counter tube with an octal base.

Replacement type ZP1500.



GEIGER-MÜLLER TUBE

Halogen quenched γ radiation counter tube.

QUICK REFERENCE DATA	
Effective range	10^{-4} to 1 R/h
Plateau	400 to 600 V
Recommended supply voltage	500 V
Cr Fe cathode	250 mg/cm^2

DIMENSIONS AND CONNECTIONS

Dimensions in mm

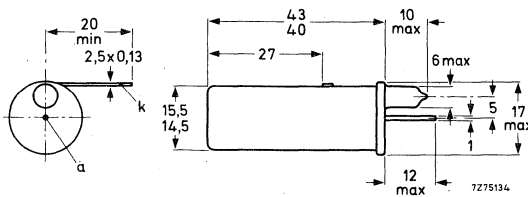

Use only anode connector
supplied with tube.

CATHODE

Thickness	250 mg/cm^2
Effective length	40 mm
Material	chrome-iron, $\approx 28\%$ Cr, $\approx 72\%$ Fe

FILLING

neon, argon, halogen

CAPACITANCE

Anode to cathode	2 pF
------------------	------

OPERATING CHARACTERISTICS ($t_{amb} = 25\text{ }^{\circ}\text{C}$) measured in circuit of Fig. 1

Starting voltage	\leq	325	V
Recommended supply voltage		450	V
Plateau	400 to	600	V
Plateau slope	\leq	0,04	%/V
Background, shielded with 50 mm Pb and 3 mm Al lining, at $V_b = 500\text{ V}$	\leq	10	count/min
Dead time at $V_b = 500\text{ V}$	\leq	90	μs

LIMITING VALUES (Absolute max. rating system)

Anode resistor	min.	4,7	$\text{M}\Omega$
Anode voltage	max.	600	V
Ambient temperature	min.	-50	$^{\circ}\text{C}$
for continuous operation	max.	+75	$^{\circ}\text{C}$
	max.	+50	$^{\circ}\text{C}$

LIFE EXPECTANCY

Life expectancy at $t_{amb} = 25\text{ }^{\circ}\text{C}$, count rate 1200 c/s 5 x 10¹⁰ count

MEASURING CIRCUIT

- $R_1 = 10\text{ M}\Omega$
- $R_2 = 220\text{ k}\Omega$
- $C_1 = 1\text{ pF}$

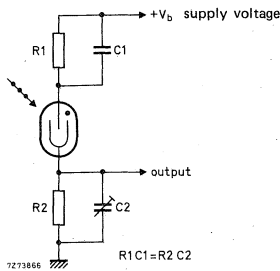
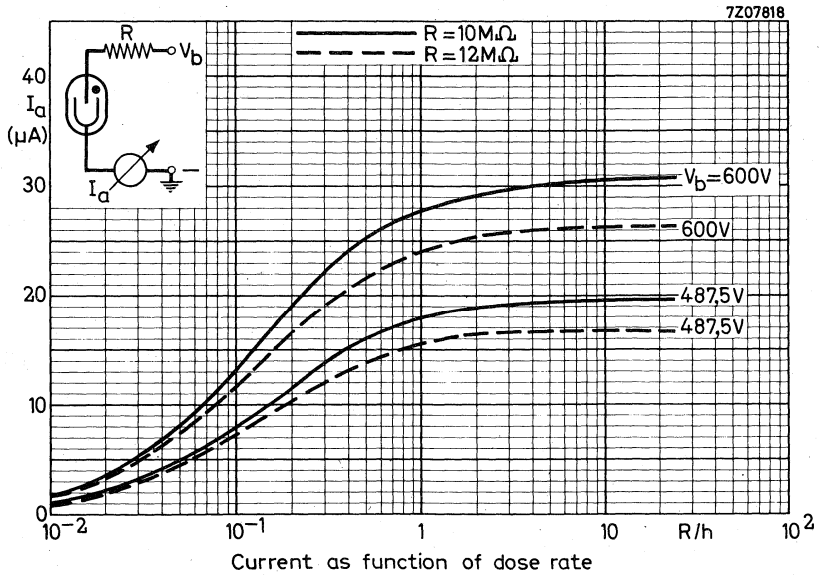
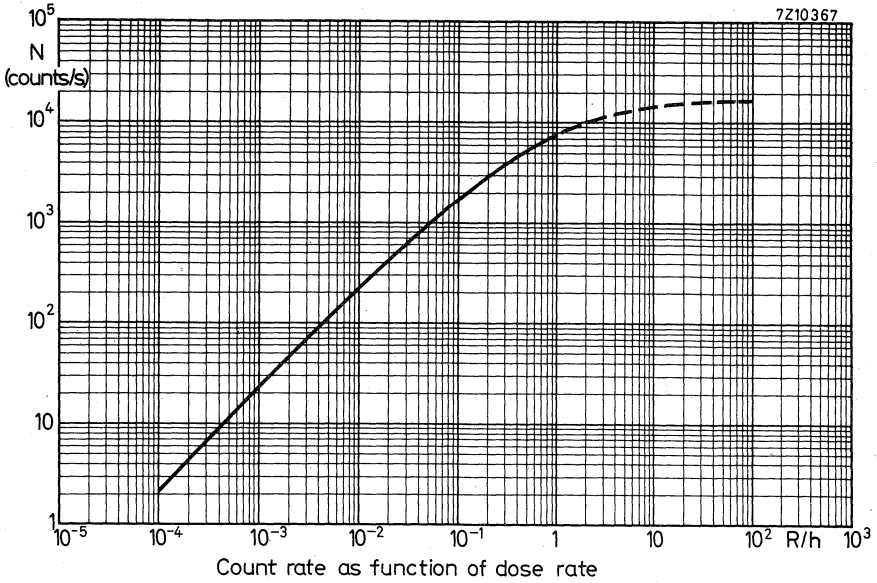
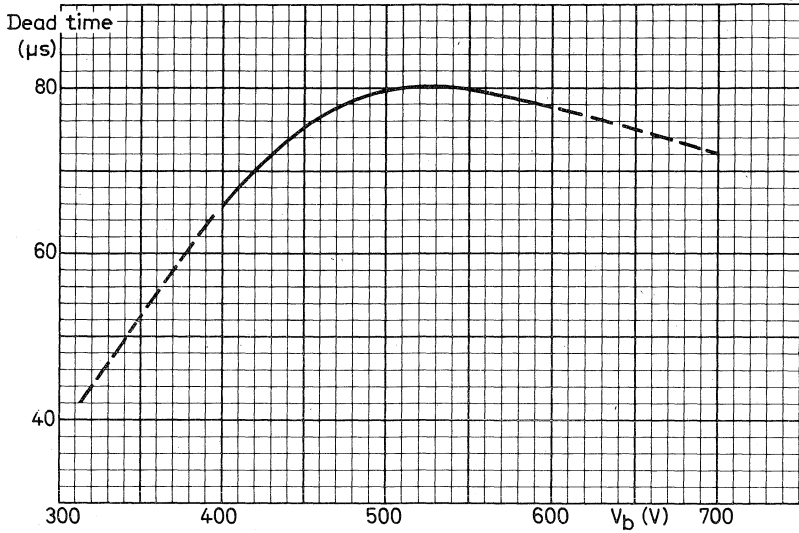

Fig. 1



7Z07819



Dead time curve

7Z07821

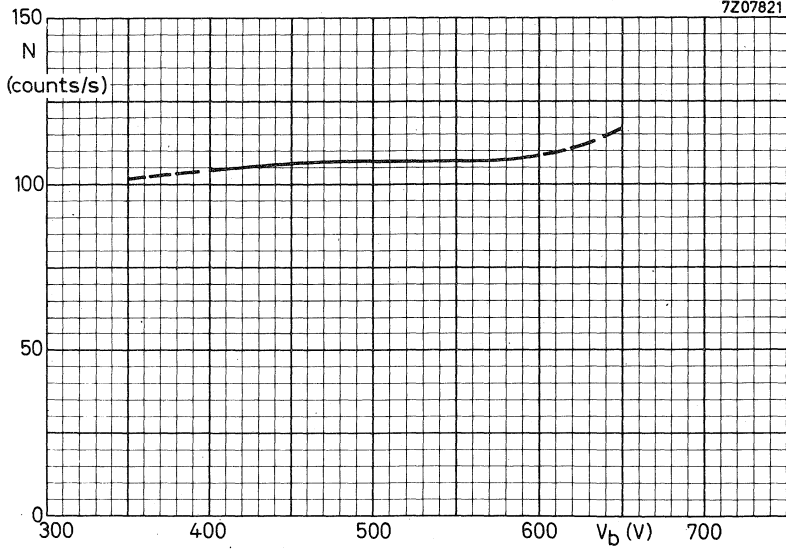

Plateau curve

GEIGER-MÜLLER TUBE

Halogen quenched γ radiation counter tube.

QUICK REFERENCE DATA	
Effective range	4×10^{-4} to 2×10^{-1} R/h
Plateau	375 to 475 V
Recommended supply voltage	420 V
Cr Fe cathode	525 mg/cm ²

DIMENSIONS AND CONNECTIONS

Dimensions in mm

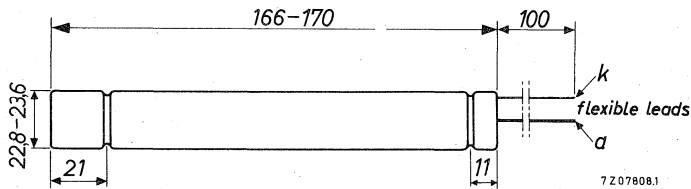

CATHODE

Thickness	525 mg/cm ²
Effective length	140 mm
Material	chrome-iron, $\approx 28\%$ Cr, $\approx 72\%$ Fe

FILLING

neon, argon, halogen

CAPACITANCE

Anode to cathode	4,5 pF
------------------	--------

OPERATING CHARACTERISTICS ($t_{amb} = 25\text{ }^{\circ}\text{C}$) measured in circuit of Fig. 1

Starting voltage	\leq	360	V
Recommended supply voltage		420	V
Plateau		375 to 475	V
Plateau slope	\leq	0,15	%/V
Background, shielded with 50 mm Pb and 3 mm Al lining at $V_b = 420\text{ V}$	\leq	50	count/min
Dead time at $V_b = 420\text{ V}$	\leq	200	μs

LIMITING VALUES (Absolute max. rating system)

Anode resistor	min.	2,2	$\text{M}\Omega$
Anode voltage	max.	475	V
Ambient temperature for continuous operation	min.	-50	$^{\circ}\text{C}$
	max.	+75	$^{\circ}\text{C}$
	max.	+50	$^{\circ}\text{C}$

LIFE EXPECTANCY

Life expectancy at $t_{amb} = 25\text{ }^{\circ}\text{C}$ 5×10^{10} count

MEASURING CIRCUIT

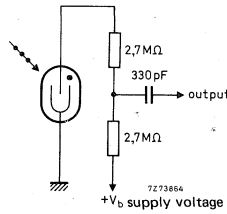
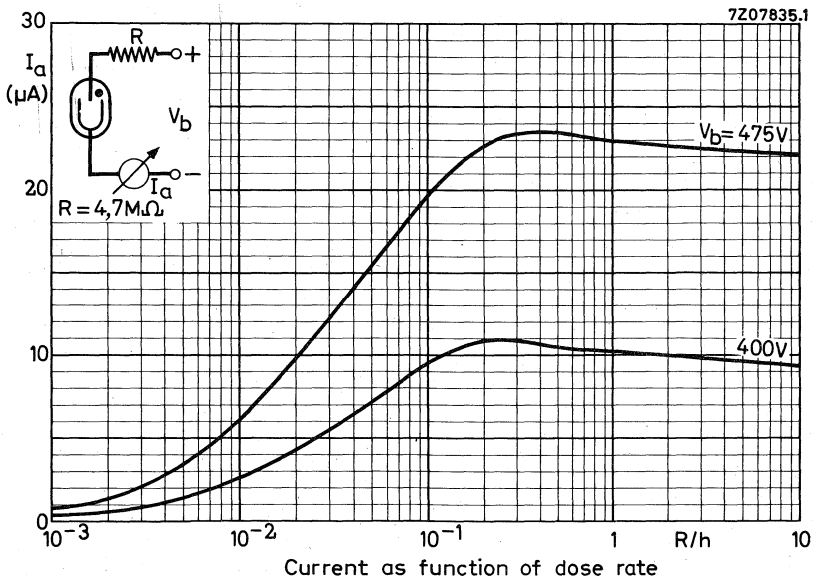
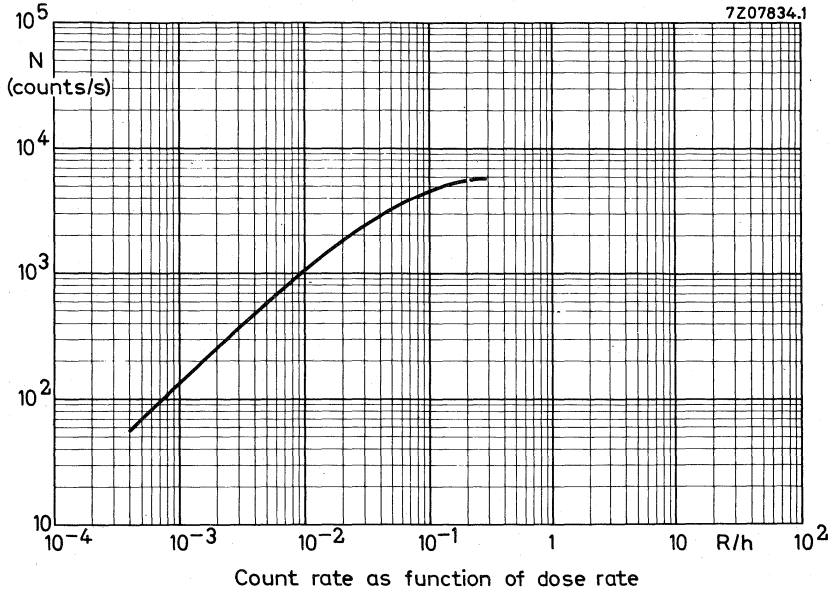
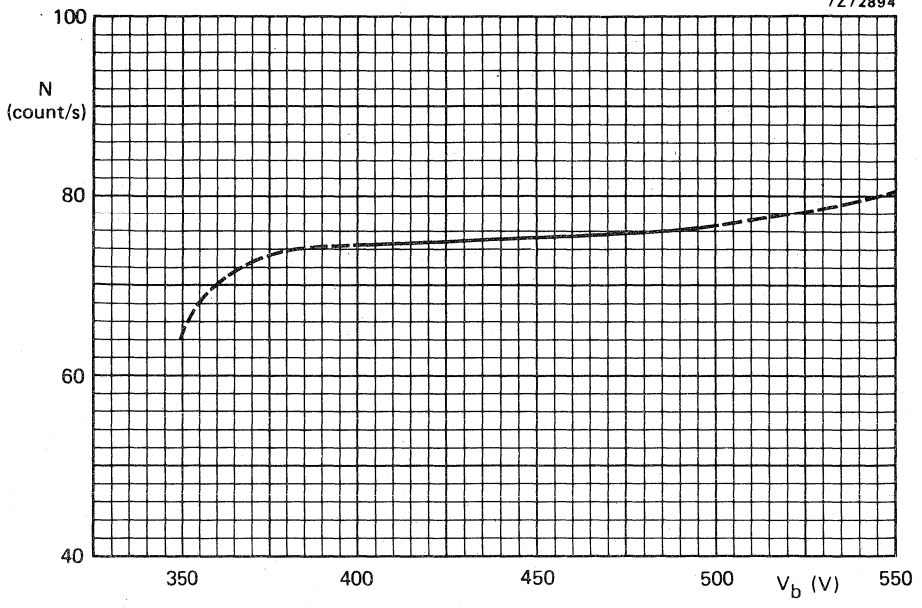

Fig. 1



7Z72894



7Z70993.1

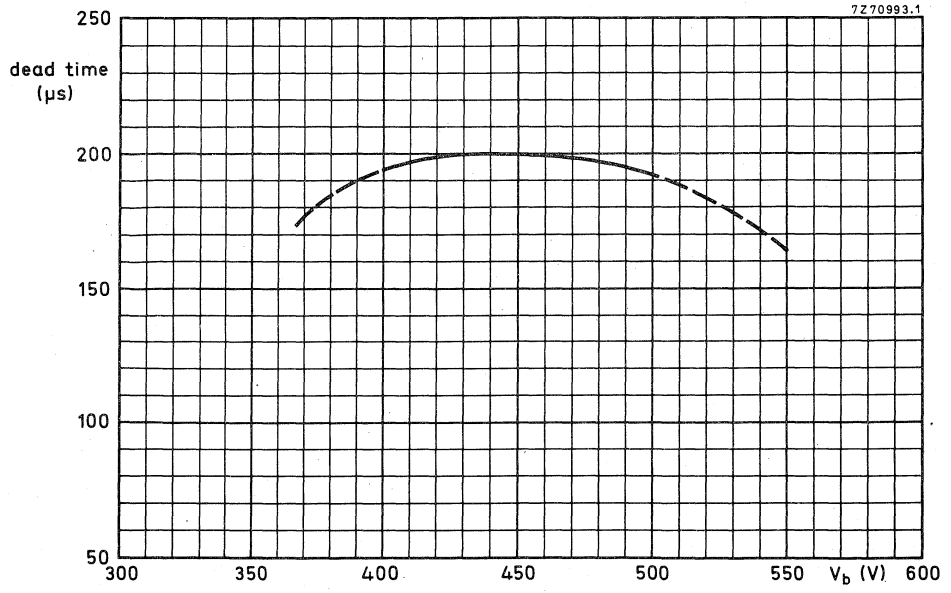

dead time curve

ZP1220

(18545) (MX145)

GEIGER-MÜLLER TUBE

Halogen quenched γ radiation counter tube.

QUICK REFERENCE DATA

Effective range	10^{-4} to 10^{-1}	R/h
Plateau	380 to 480	V
Recommended supply voltage	420	V
Cr Fe cathode	525	mg/cm ²

DIMENSIONS AND CONNECTIONS

Dimensions in mm

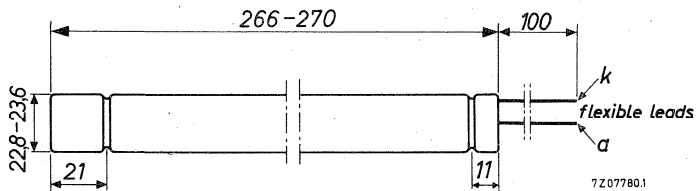

CATHODE

Thickness 525 mg/cm²

Effective length 240 mm

Material chrome-iron, $\approx 28\%$ Cr, $\approx 72\%$ Fe

FILLING

neon, argon, halogen

CAPACITANCE

Anode to cathode 10 pF

OPERATING CHARACTERISTICS ($t_{amb} = 25\text{ }^{\circ}\text{C}$) measured in circuit of Fig. 1

Starting voltage	\leq	360	V
Recommended supply voltage		420	V
Plateau		380 to 480	V
Plateau slope	\leq	0,10	%/V
Background, shielded with 50 mm Pb and 3 mm Al lining, at $V_b = 420\text{ V}$	\leq	90	count/min
Dead time at $V_b = 420\text{ V}$	\leq	200	μs

LIMITING VALUES (Absolute max. rating system)

Anode resistor	min.	2,7	$\text{M}\Omega$
Anode voltage	max.	480	V
Ambient temperature for continuous operation	min.	-50	$^{\circ}\text{C}$
	max.	+75	$^{\circ}\text{C}$
	max.	+50	$^{\circ}\text{C}$

LIFE EXPECTANCY

Life expectancy at $t_{amb} = 25\text{ }^{\circ}\text{C}$ 5 x 10¹⁰ count

MEASURING CIRCUIT

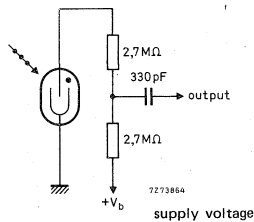
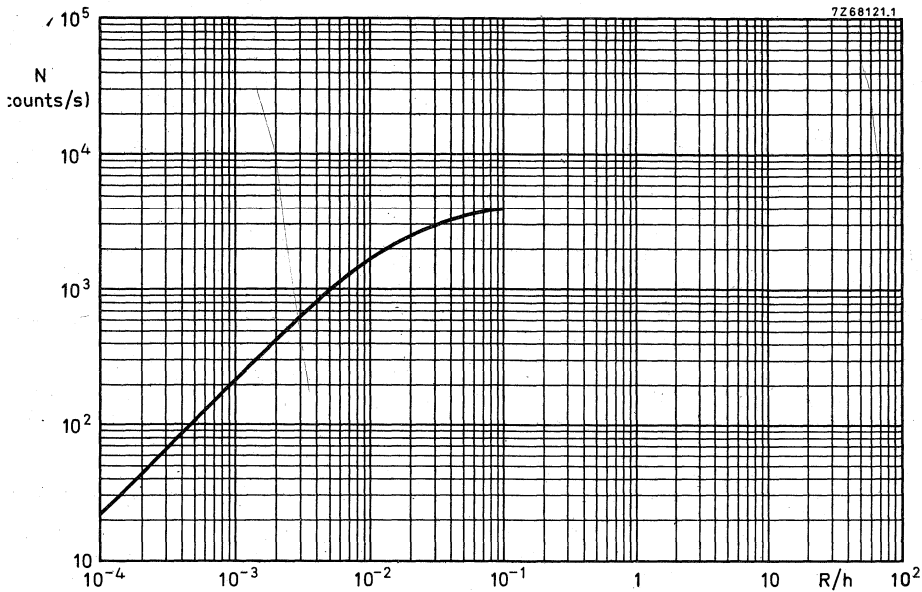
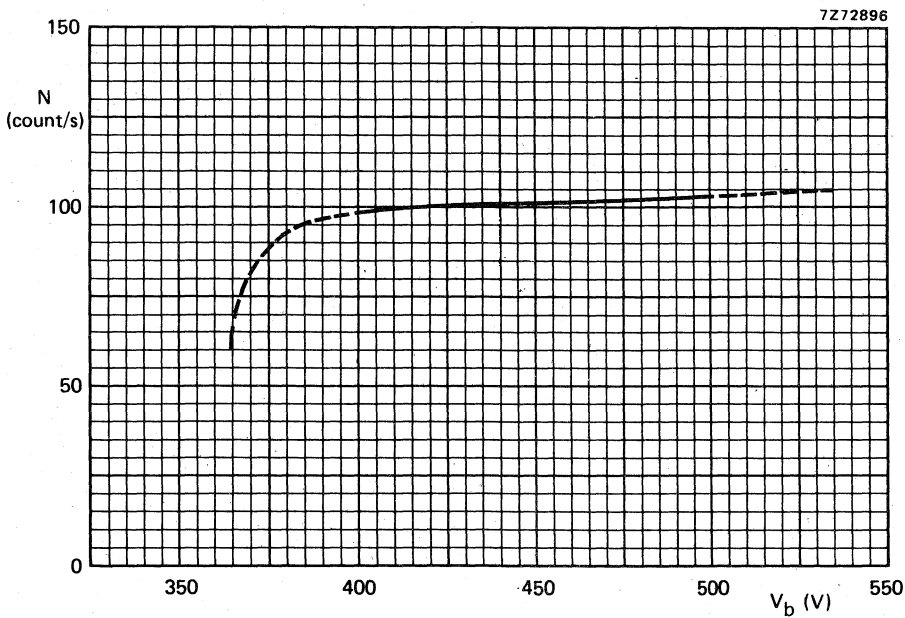
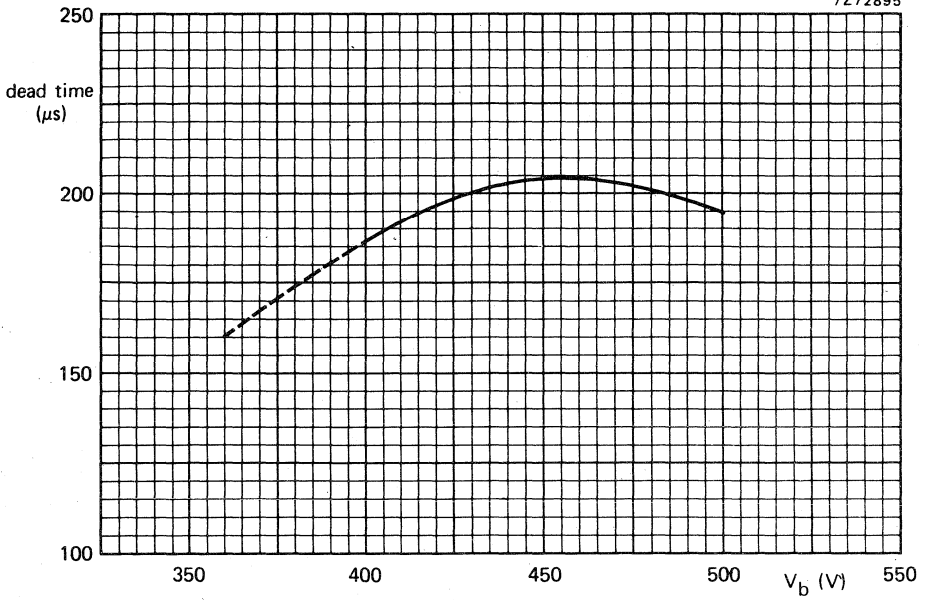

Fig. 1



Count rate as function of dose rate





ZPI300

(18529)

(MX163)

GEIGER-MÜLLER TUBE

Halogen quenched radiation counter tube for the measurement of γ and high energy β ($> 0,5$ MeV) radiation.

QUICK-REFERENCE DATA

Effective range	10^{-2} to 2×10^3	R/h
Plateau	500 to 600	V
Recommended supply voltage	550	V
Cr Fe cathode	80 to 100	mg/cm ²

DIMENSIONS AND CONNECTIONS

Dimensions in mm

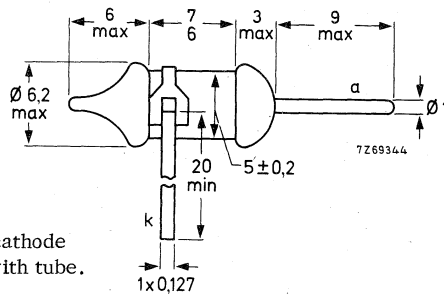

Use only anode and cathode connector supplied with tube.

CATHODE

Thickness

80 to 100 mg/cm²

Effective length

8 mm

Material

chrome-iron, $\approx 28\%$ Cr, $\approx 72\%$ Fe

FILLING

helium, neon, halogen

CAPACITANCE

Anode to cathode

0,7 pF

OPERATING CHARACTERISTICS ($t_{amb} = 25\text{ }^{\circ}\text{C}$) measured in circuit of Fig. 1

Starting voltage	\leq	400	V
Recommended supply voltage		550	V
Plateau	500 to	600	V
Plateau slope	\leq	0,3	%/V
Background, shielded with 50 mm Pb and 3 mm Al lining, at $V_b = 550\text{ V}$	\leq	1	count/min
Dead time at $V_b \leq 550\text{ V}$	\leq	11	μs

LIMITING VALUES (Absolute max. rating system)

Anode resistor	min.	2,2	$\text{M}\Omega$
Anode voltage	max.	600	V
Ambient temperature	min.	-40	$^{\circ}\text{C}$
for continuous operation	max.	+75	$^{\circ}\text{C}$
	max.	+50	$^{\circ}\text{C}$

LIFE EXPECTANCY

Life expectancy at $t_{amb} = 25\text{ }^{\circ}\text{C}$, count rate 3200 c/s 10^{10} count

MEASURING CIRCUIT

$$R_1 = 2,2\text{ M}\Omega$$

$$R_2 = 47\text{ k}\Omega$$

$$C_1 = 1\text{ pF}$$

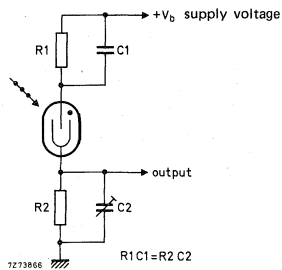
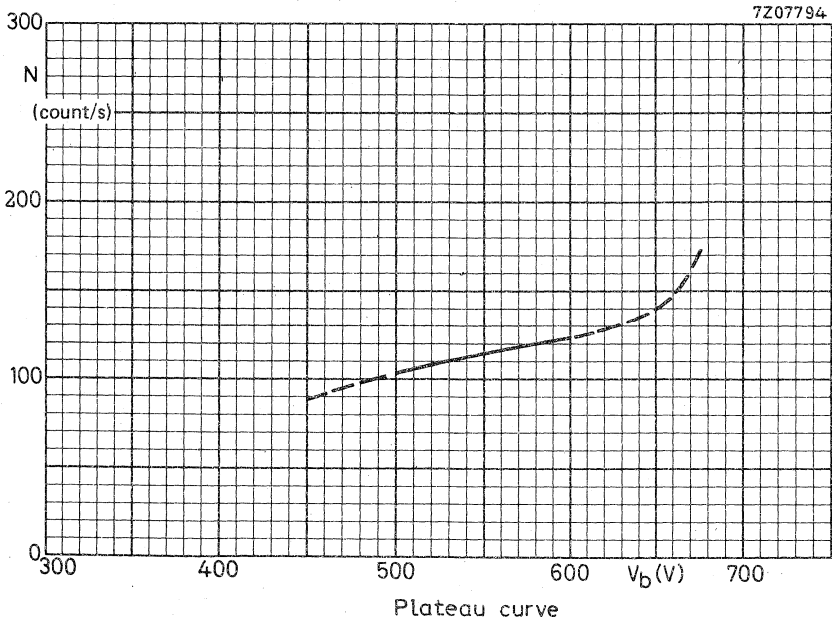
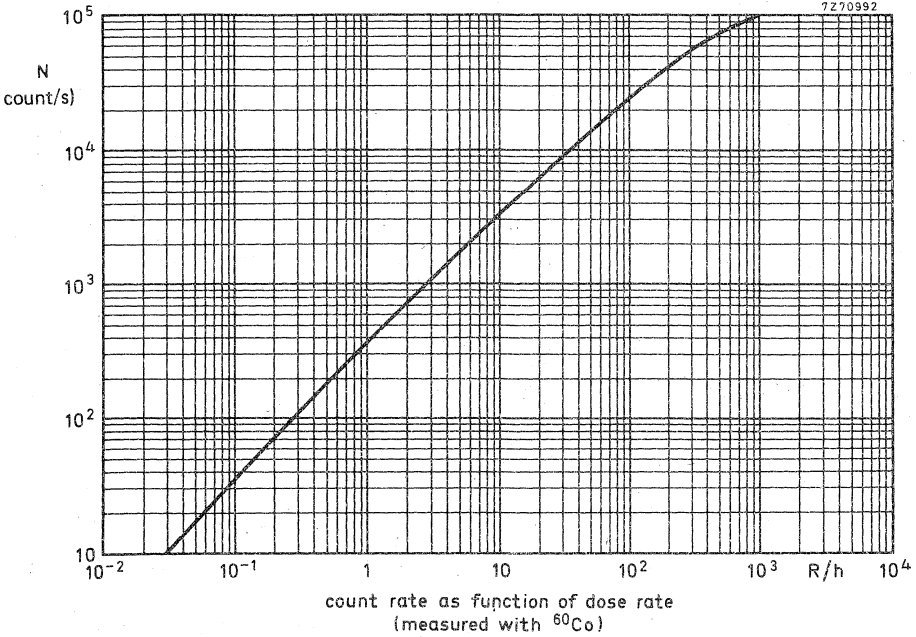
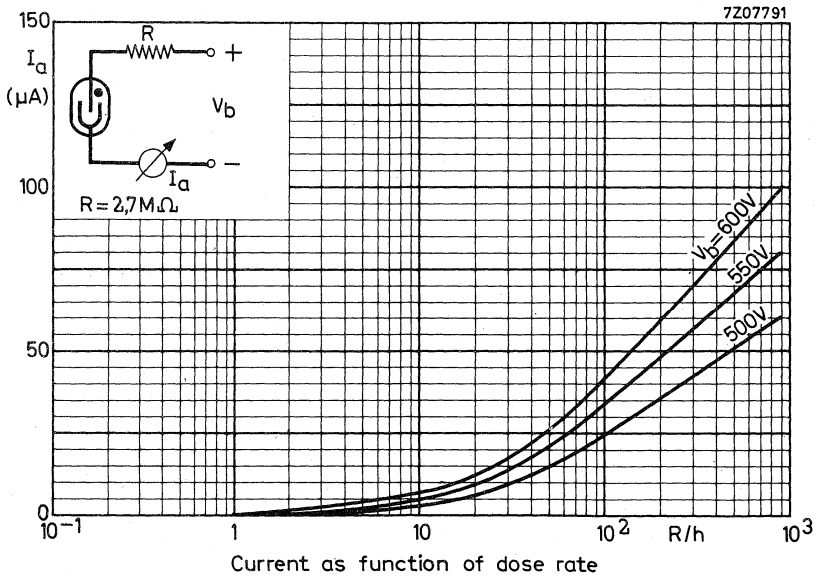
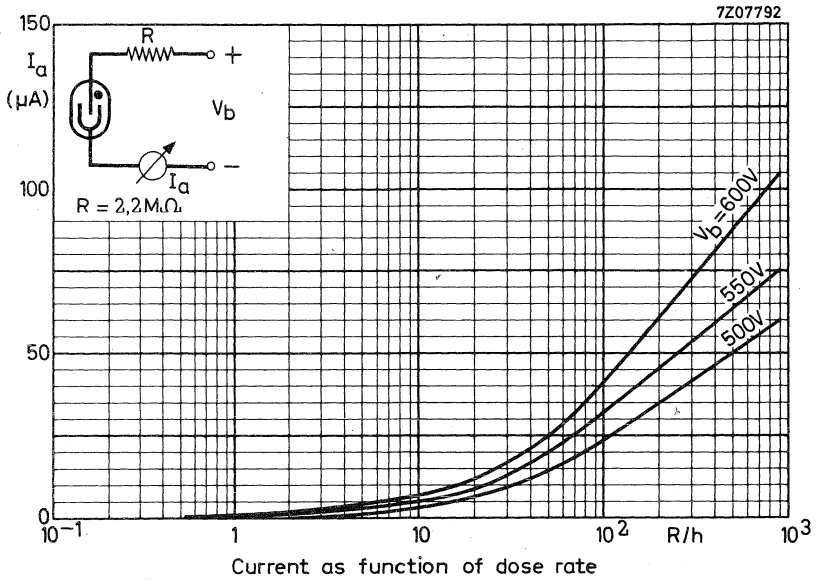

Fig. 1





GEIGER-MÜLLER TUBE

Halogen quenched radiation counter tube for the measurement of γ and high energy β ($> 0,5 \text{ MeV}$) radiation.

QUICK REFERENCE DATA		
Effective range	10^{-3} to 3×10^2	R/h
Plateau	500 to 650	V
Recommended supply voltage	575	V
Cr Fe cathode	80 to 100	mg/cm ²

DIMENSIONS AND CONNECTIONS

Dimensions in mm

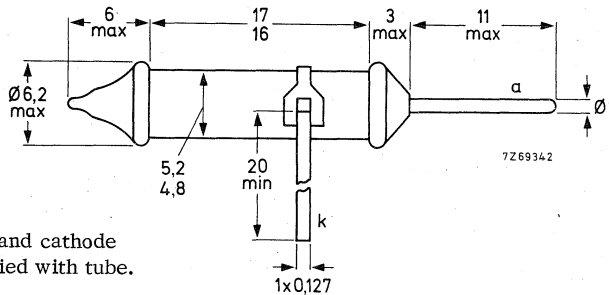

Use only anode and cathode connector supplied with tube.

CATHODE

Thickness	80 to 100	mg/cm ²
Effective length	16	mm
Material	chrome-iron, $\approx 28\% \text{ Cr}$, $\approx 72\% \text{ Fe}$	

FILLING

helium, neon, halogen

CAPACITANCE

Anode to cathode	1	pF
------------------	---	----

OPERATING CHARACTERISTICS ($t_{amb} = 25\text{ }^{\circ}\text{C}$) measured in circuit of Fig. 1

Starting voltage	\leq	380	V
Recommended supply voltage		575	V
Plateau		500 to 650	V
Plateau slope	\leq	0, 15	%/V
Background, shielded with 50 mm Pb and 3 mm Al lining, at $V_b = 575\text{ V}$	\leq	2	count/min
Dead time at $V_b \leq 600\text{ V}$	\leq	15	μs

LIMITING VALUES (Absolute max. rating system)

Anode resistor	min.	2, 2	$\text{M}\Omega$
Anode voltage	max.	650	V
Ambient temperature	min.	-40	$^{\circ}\text{C}$
for continuous operation	max.	+75	$^{\circ}\text{C}$
	max.	+50	$^{\circ}\text{C}$

LIFE EXPECTANCY

Life expectancy at $t_{amb} = 25\text{ }^{\circ}\text{C}$, count rate 4500 c/s 5×10^{10} count

MEASURING CIRCUIT

- $R_1 = 2, 2\text{ M}\Omega$
- $R_2 = 47\text{ k}\Omega$
- $C_1 = 1\text{ pF}$

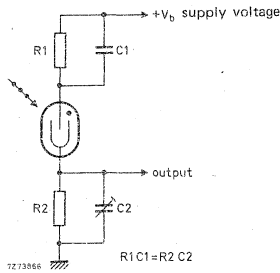
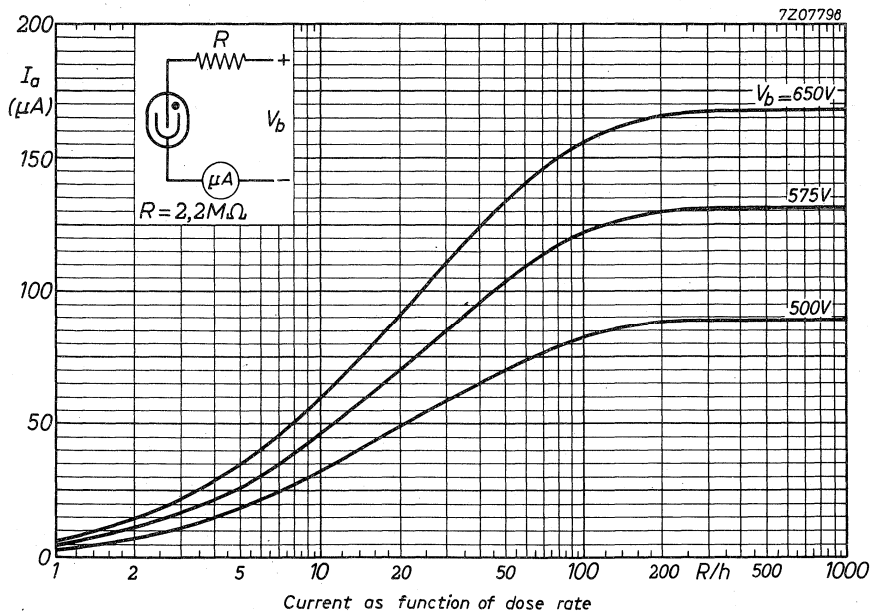
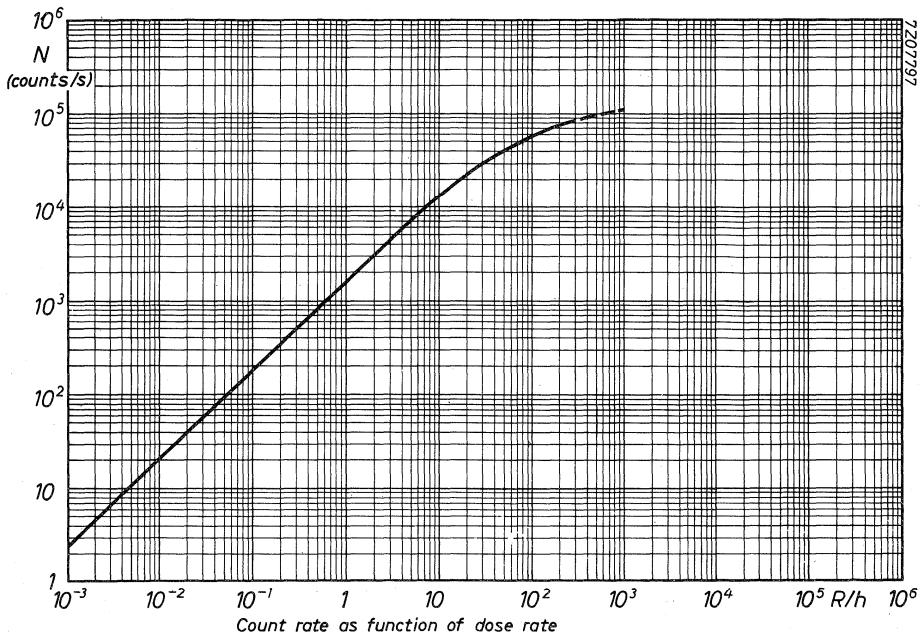
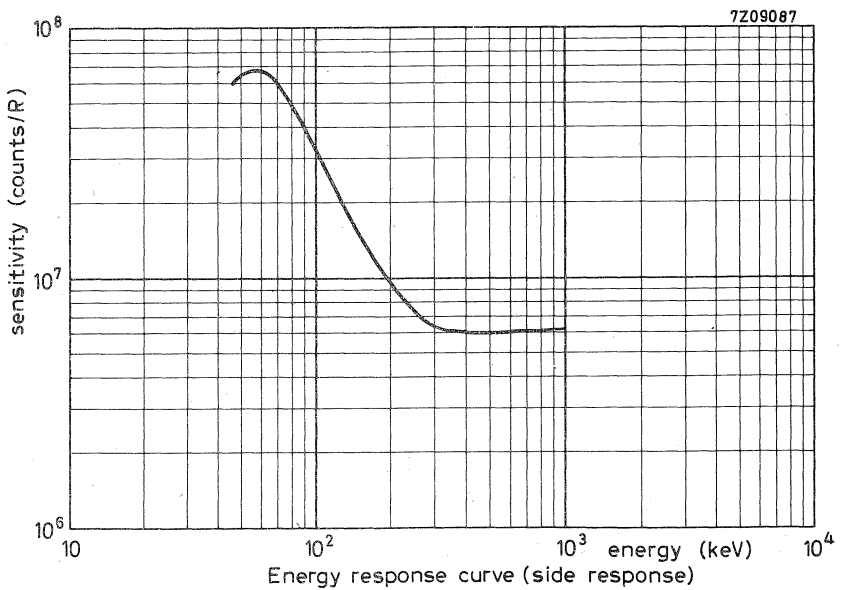
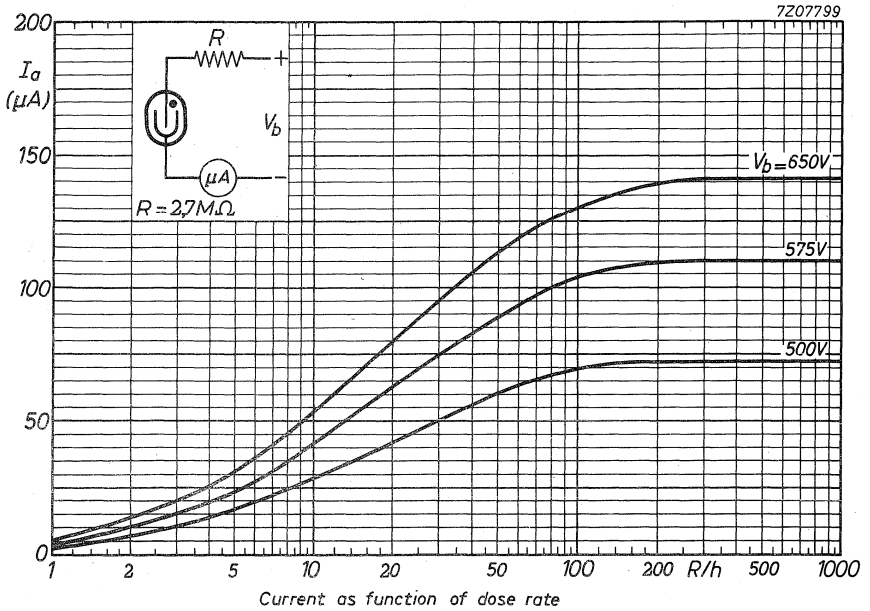
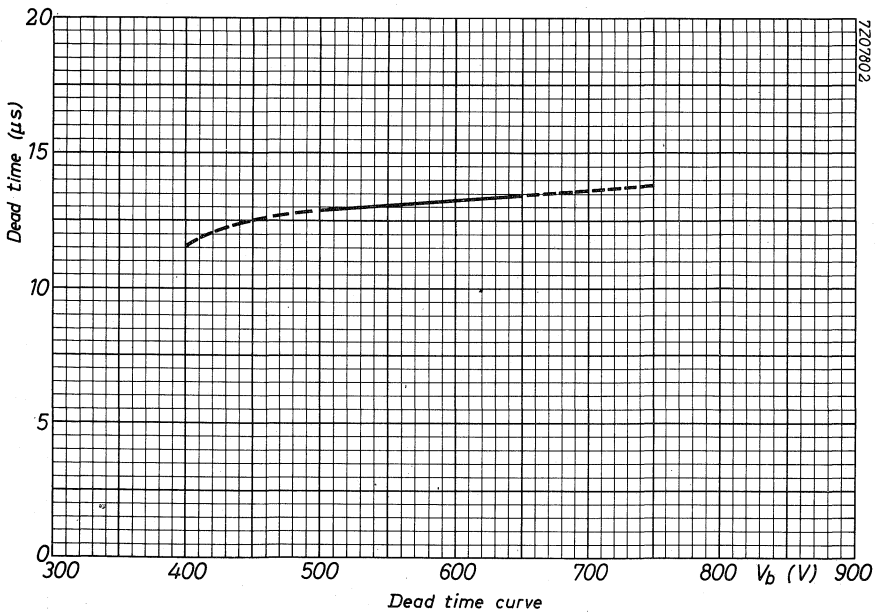
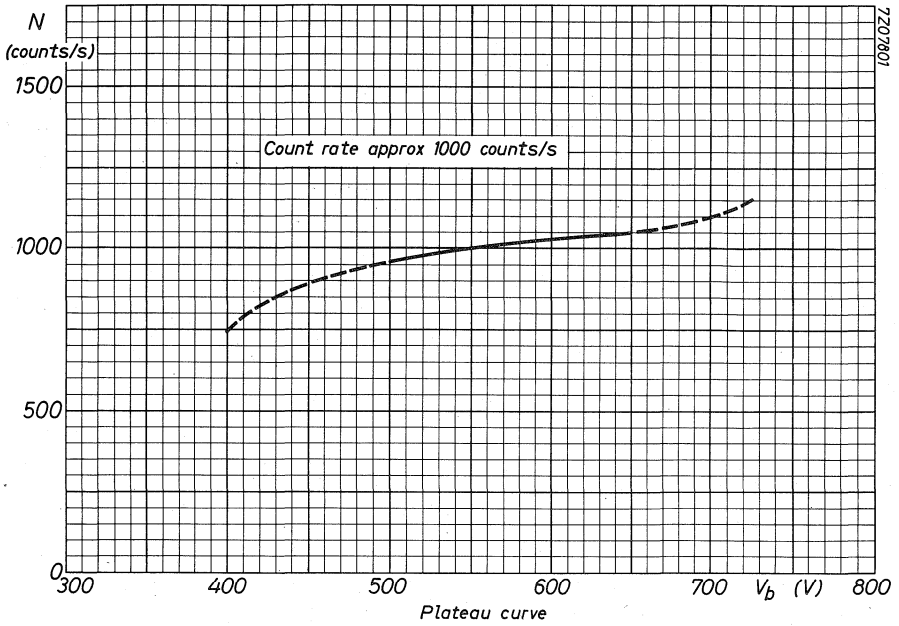

Fig. 1







GEIGER-MÜLLER TUBE

Halogen quenched radiation counter tube for the measurement of γ radiation.

The tube is provided with a filter. The energy response is flat within 15% referred to the 1,33 MeV point.

QUICK REFERENCE DATA		
Effective range	10^{-3} to 3×10^2	R/h
Energy range	40 to 3000	keV
Plateau	500 to 650	V
Recommended supply voltage	575	V
Cr Fe cathode	80 to 100	mg/cm ²
Sn filter	2	mm

DIMENSIONS AND CONNECTIONS

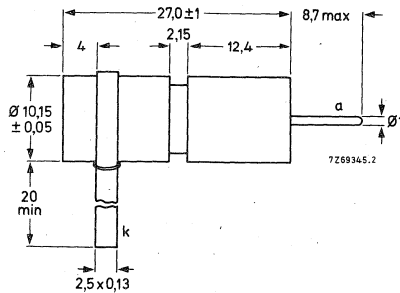

Use only cathode connector
supplied with tube.

FILTER

Thickness	2	mm
Material	tin	

CATHODE

Thickness	80 to 100	mg/cm ²
Effective length	16	mm
Material	chrome-iron, $\approx 28\%$ Cr, $\approx 72\%$ Fe	

FILLING

helium, neon, halogen

CAPACITANCES

Anode to cathode 2 pF

OPERATING CHARACTERISTICS ($t_{amb} = 25\text{ }^{\circ}\text{C}$) measured in circuit of Fig. 1

Starting voltage	\leq	380 V
Recommended operating voltage		575 V
Plateau	500 to	650 V
Plateau slope	\leq	0,15 %/V
Background, shielded with 50 mm Pb and 3 mm Al lining, at $V_b = 575\text{ V}$	\leq	2 count/min
Dead time at $V_b = 600\text{ V}$	\leq	15 μs

LIMITING VALUES (Absolute max. rating system)

Anode resistor	min.	2,2 $\text{M}\Omega$
Anode voltage	max.	650 V
Ambient temperature	min.	-40 $^{\circ}\text{C}$
for continuous operation	max.	+75 $^{\circ}\text{C}$
	max.	+50 $^{\circ}\text{C}$

LIFE EXPECTANCY

Life expectancy at $t_{amb} = 25\text{ }^{\circ}\text{C}$, count rate 4500 c/s 5 x 10¹⁰ count

MEASURING CIRCUITS

$R_1 = 2,2\text{ M}\Omega$
 $R_2 = 47\text{ k}\Omega$
 $C_1 = 1\text{ pF}$

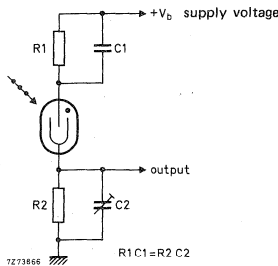
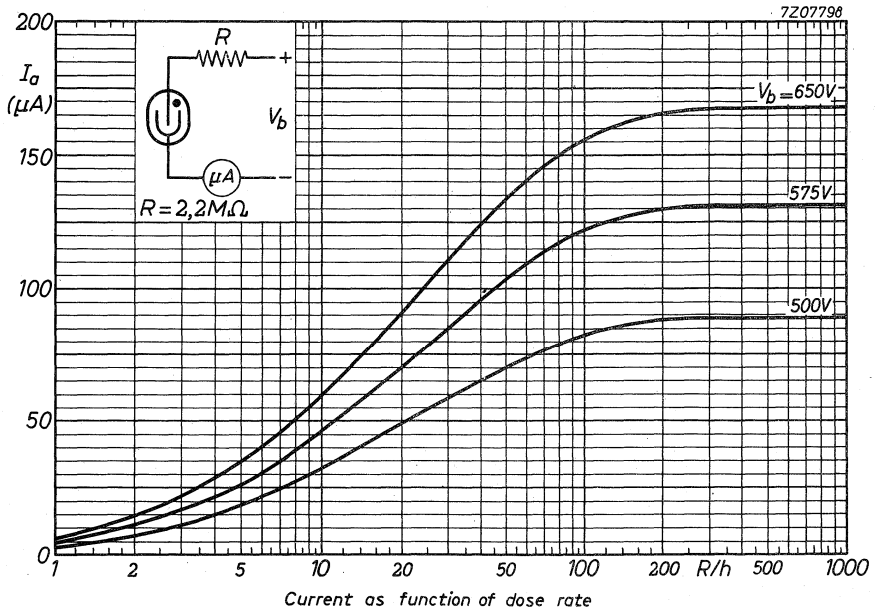
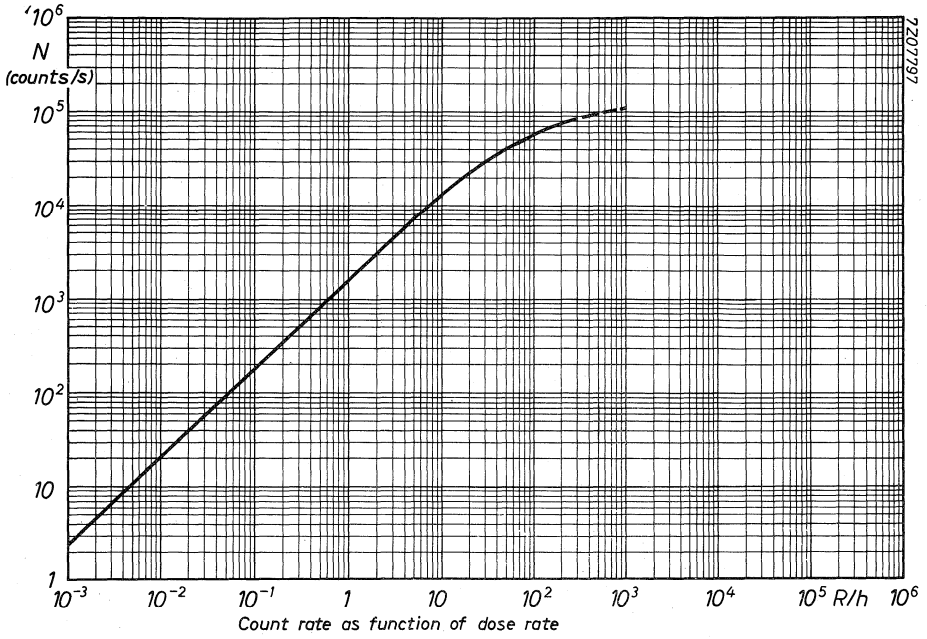
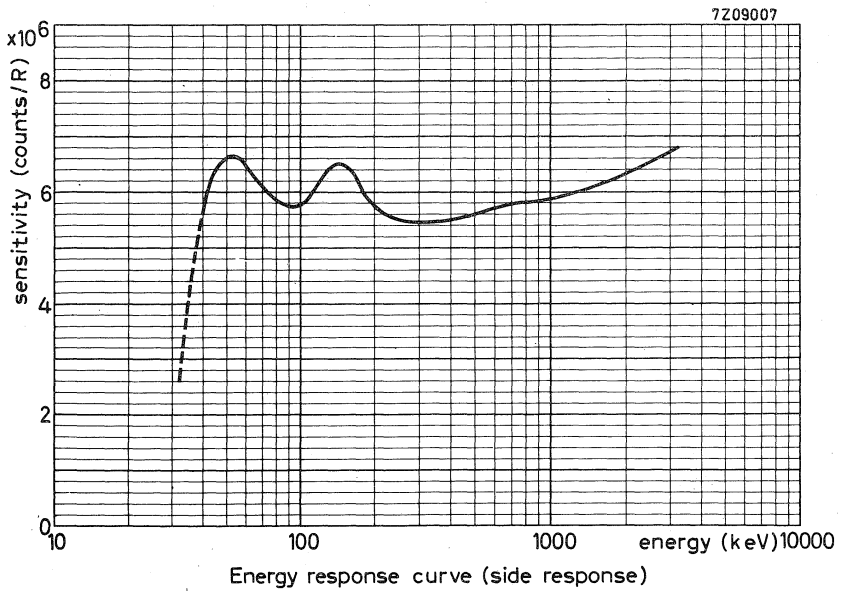
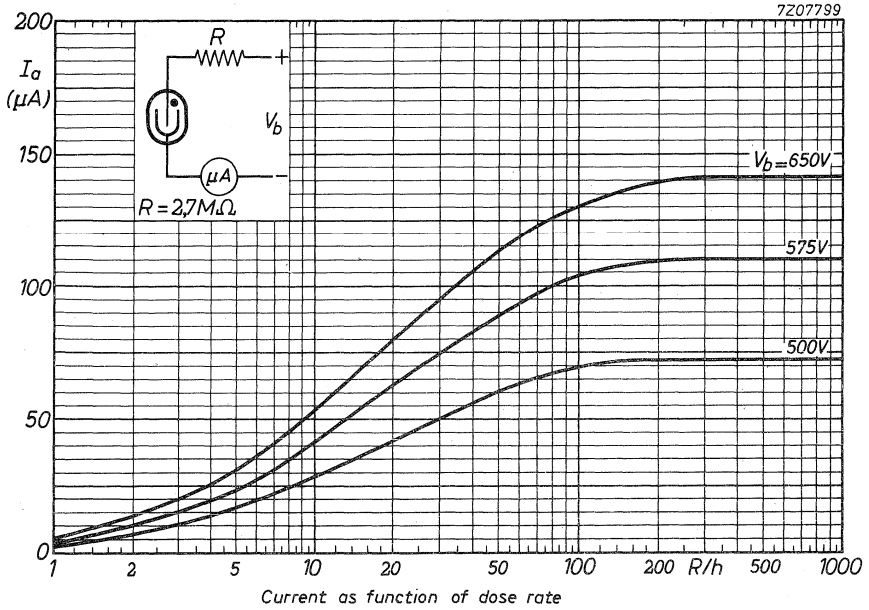
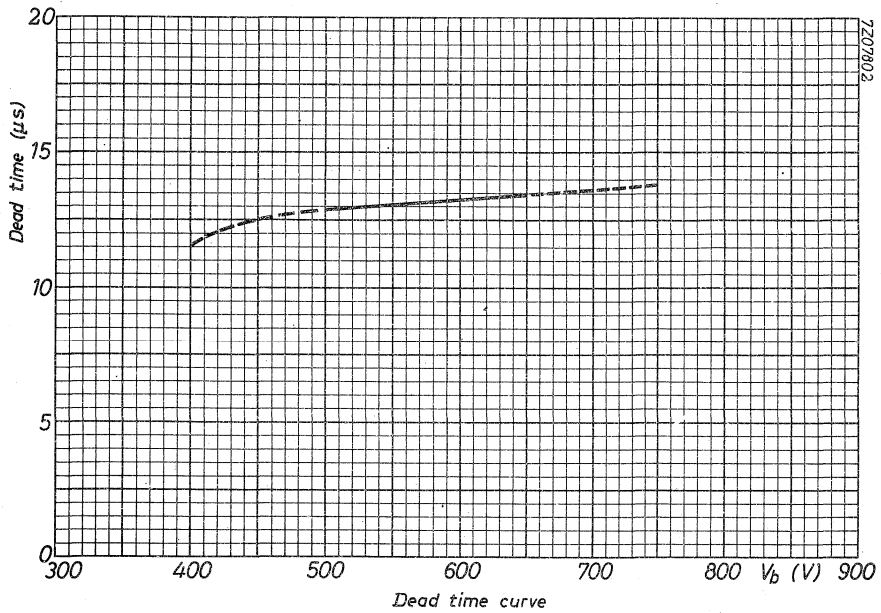
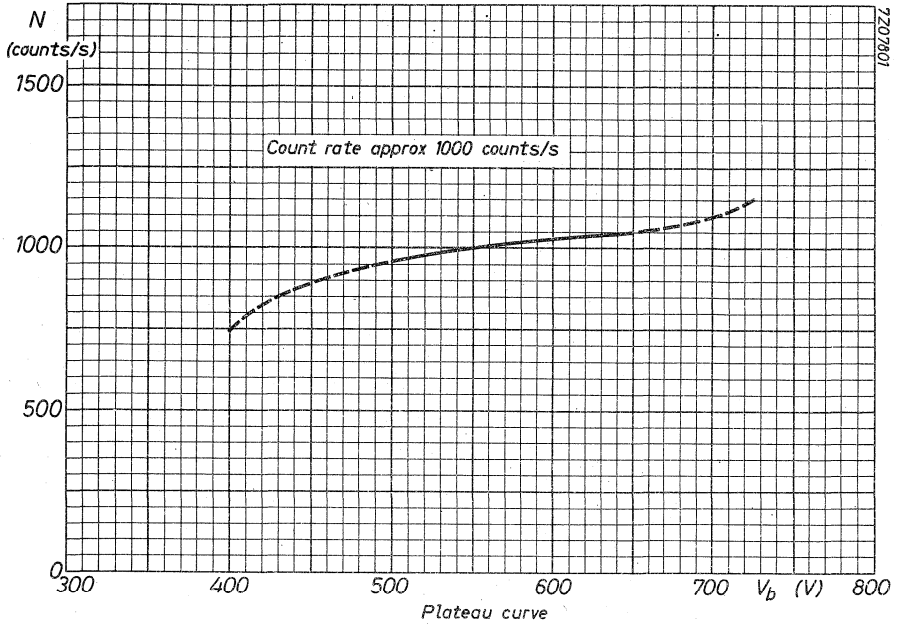
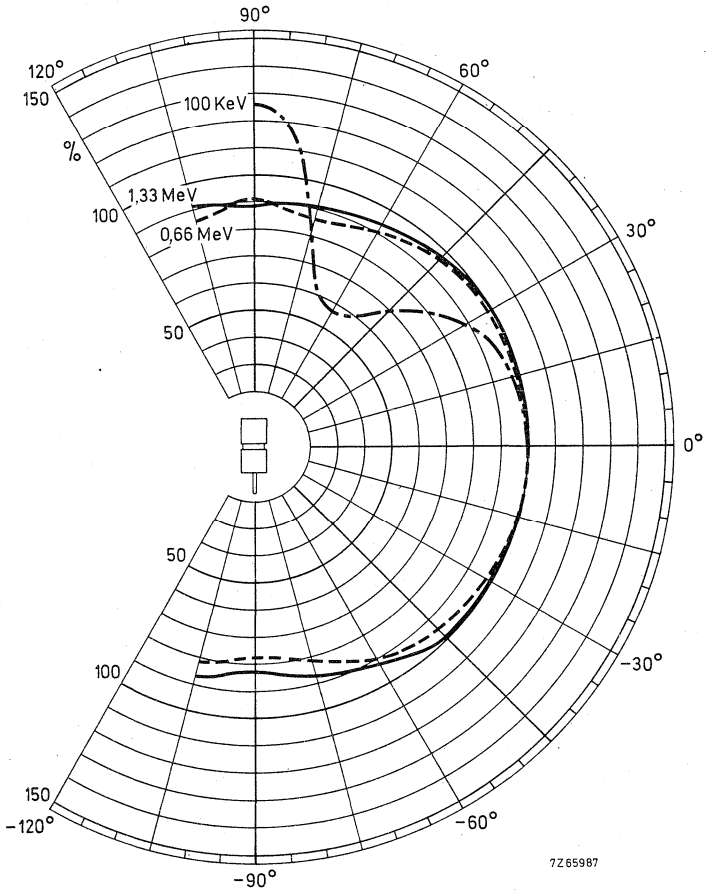

Fig. 1









GEIGER-MÜLLER TUBE

Halogen quenched β ($> 0,25$ MeV) and γ radiation counter tube.

QUICK REFERENCE DATA	
Effective range	10^{-3} to 10^2 R/h
Plateau	500 to 650 V
Recommended supply voltage	575 V
Cr Fe cathode	32 to 40 mg/cm^2

DIMENSIONS AND CONNECTIONS

Dimensions in mm

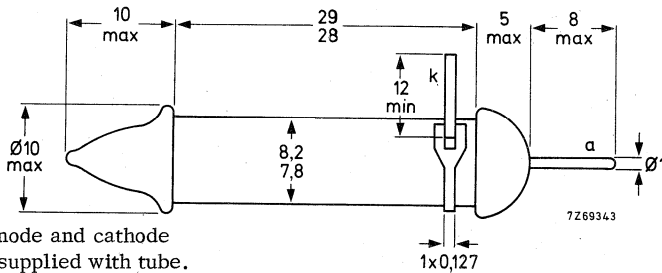

Use only anode and cathode connector supplied with tube.

CATHODE

Thickness	32 to 40 mg/cm^2
Effective length	28 mm
Material	chrome-iron, $\approx 28\%$ Cr, $\approx 72\%$ Fe

FILLING

neon, argon, halogen

CAPACITANCE

Anode to cathode	1,1 pF
------------------	--------

OPERATING CHARACTERISTICS ($t_{amb} = 25\text{ }^{\circ}\text{C}$) measured in circuit of Fig. 1

Starting voltage	≤	380	V
Recommended supply voltage		575	V
Plateau	500 to	650	V
Plateau slope	≤	0,08	%/V
Background, shielded with 50 mm Pb and 3 mm Al lining, at $V_b = 575\text{ V}$	≤	12	count/min
Dead time at $V_b = 600\text{ V}$	max.	45	μs

LIMITING VALUES (Absolute max. rating system)

Anode resistor	min.	2,2	MΩ
Anode voltage	max.	650	V
Ambient temperature for continuous operation	min.	-50	°C
	max.	+75	°C
	max.	+50	°C

LIFE EXPECTANCY

Life expectancy at $t_{amb} = 25\text{ }^{\circ}\text{C}$, count rate 800 c/s 5 x 10¹⁰ count

MEASURING CIRCUIT

$R_1 = 4,7\text{ M}\Omega$

$R_2 = 100\text{ k}\Omega$

$C_1 = 1\text{ pF}$

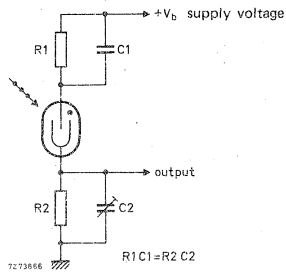
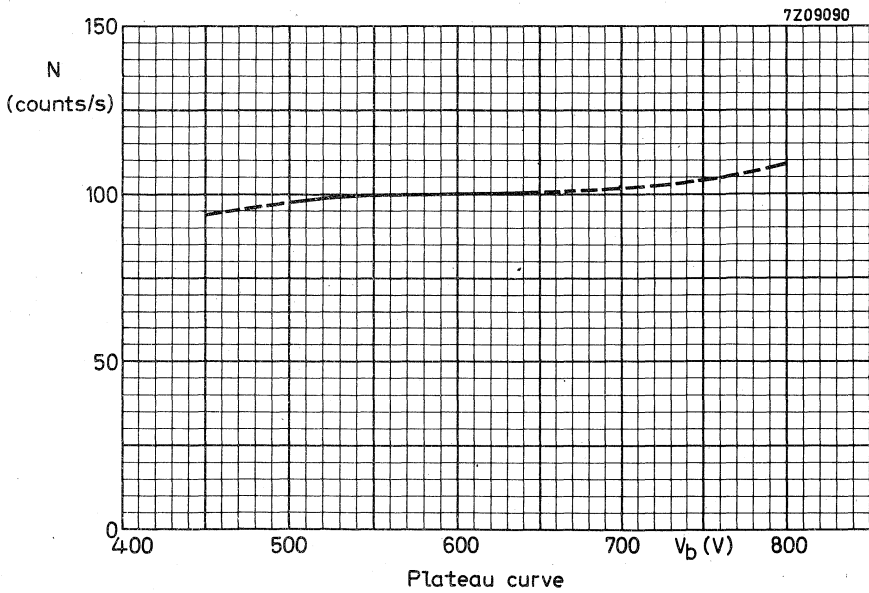
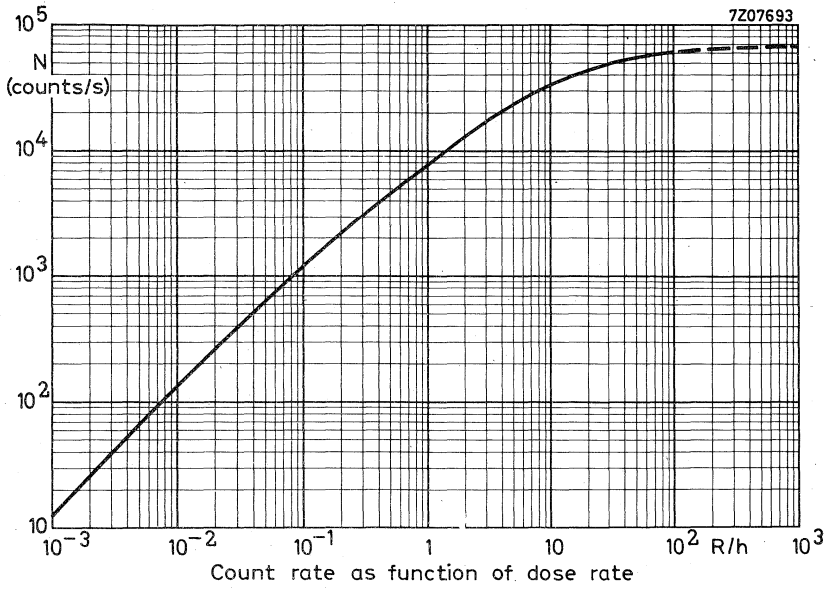
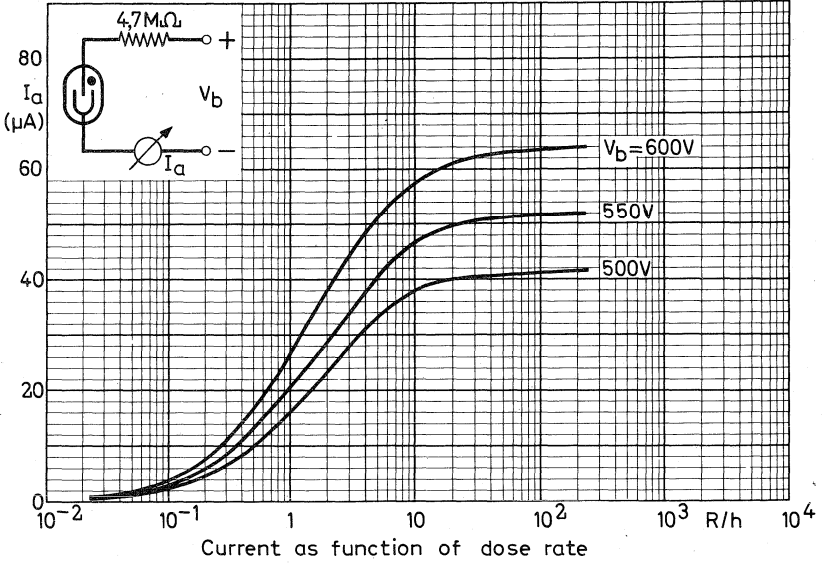

Fig. 1



7Z07692



7Z07691

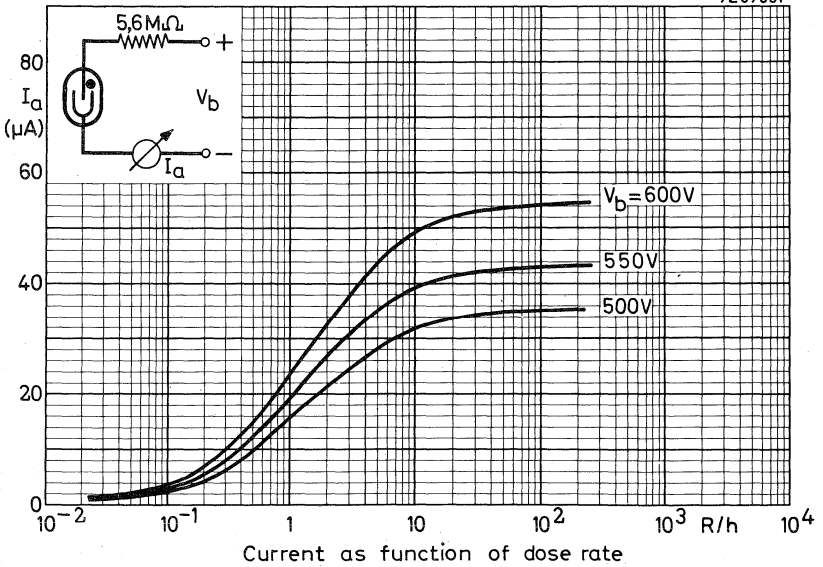

7207695

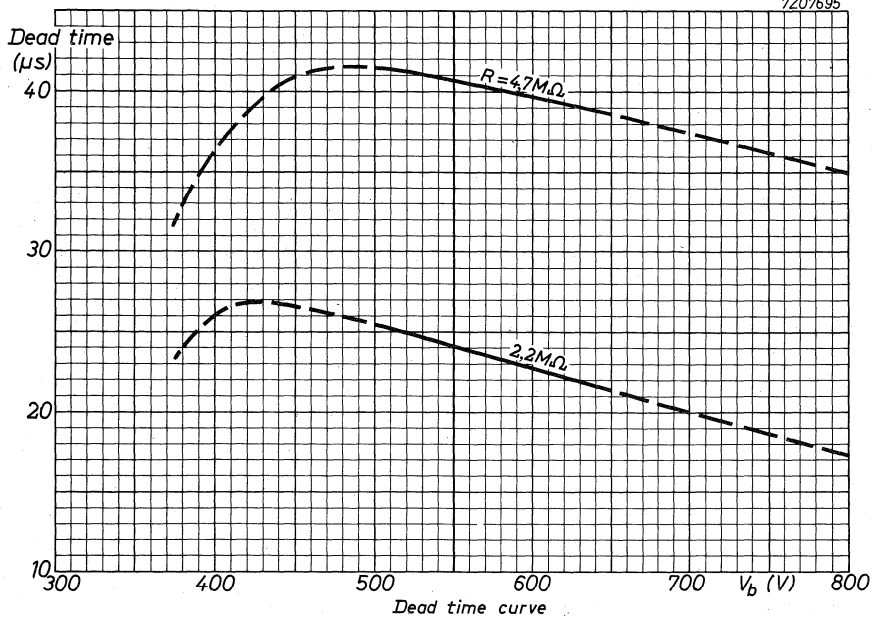

GEIGER-MÜLLER TUBE

Halogen quenched β ($> 0,3$ MeV) and γ radiation counter tube suitable for use in damp and/or saline atmosphere.

QUICK REFERENCE DATA

Effective range	10^{-3} to 10 R/h
Plateau	450 to 800 V
Recommended supply voltage	625 V
Cr Fe cathode	40 to 60 mg/cm ²

DIMENSIONS AND CONNECTIONS

Dimensions in mm

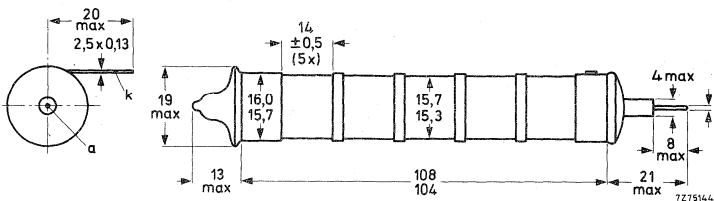

Use only anode connector supplied with tube.

CATHODE

Construction	cylindrical wall with strengthening rings
Thickness between the strengthening rings	40 to 60 mg/cm ²
Total effective length	75 mm
Material	chrome-iron, $\approx 28\%$ Cr, $\approx 72\%$ Fe

FILLING

neon, argon, halogen

CAPACITANCE

Anode to cathode	4 pF
------------------	------

OPERATING CHARACTERISTICS ($t_{amb} = 25\text{ }^{\circ}\text{C}$) measured in circuit of Fig. 1

Starting voltage	\leq	400	V
Recommended supply voltage		625	V
Plateau	450 to	800	V
Plateau slope	\leq	0,02	%/V
Background shielded with 50 mm Pb and 3 mm Al lining, at $V_b = 625\text{ V}$	\leq	30	count/min
Dead time at $V_b = 600\text{ V}$	\leq	70	μs

LIMITING VALUES (Absolute max. rating system)

Anode resistor	min.	1	$\text{M}\Omega$
Anode voltage	max.	800	V
Ambient temperature for continuous operation	min.	-50	$^{\circ}\text{C}$
	max.	+75	$^{\circ}\text{C}$
	max.	+50	$^{\circ}\text{C}$

LIFE EXPECTANCY

Life expectancy at $t_{amb} = 25\text{ }^{\circ}\text{C}$, count rate 600 c/s 5×10^{10} count

MEASURING CIRCUIT

$R = 2,2\text{ M}\Omega$

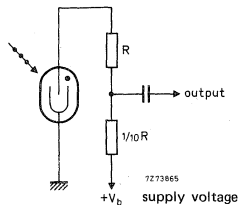
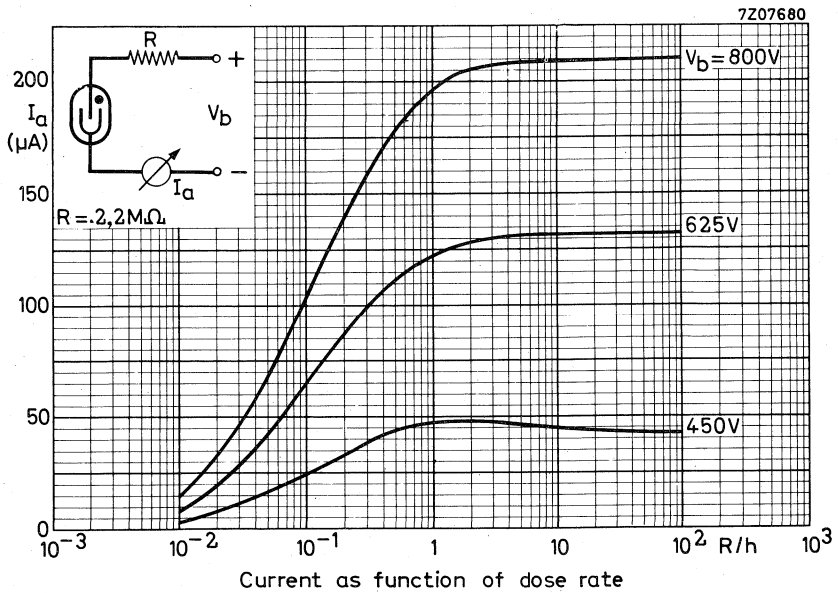
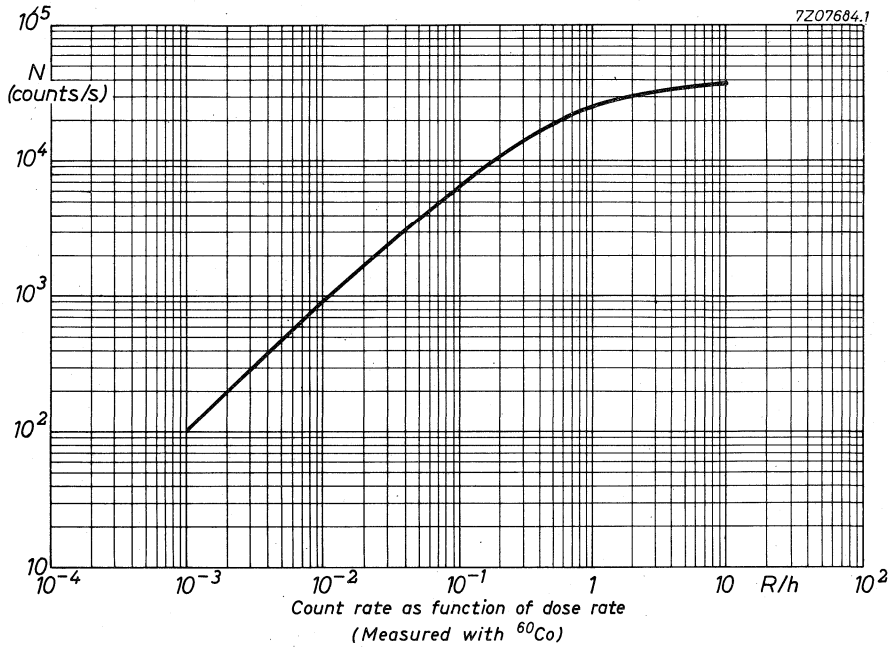
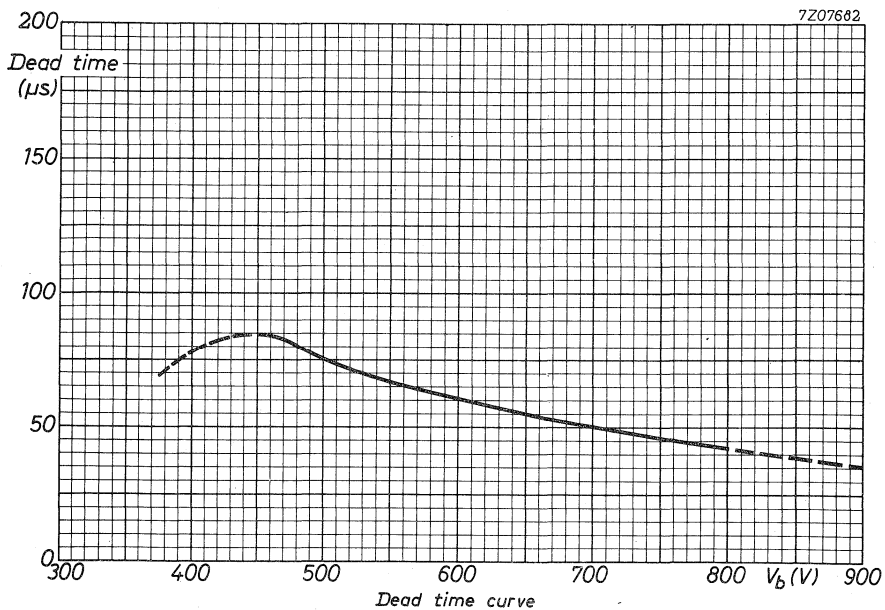
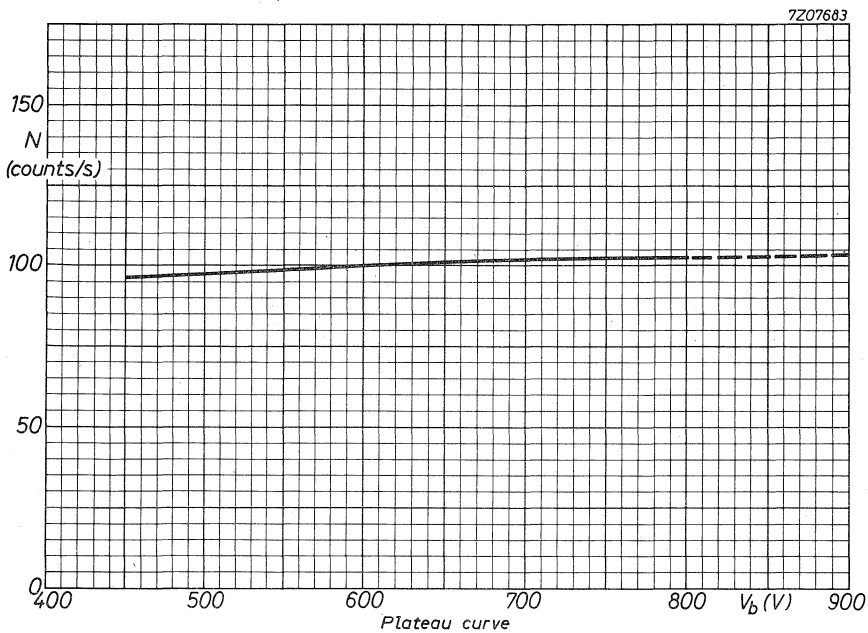

Fig. 1

REMARK

The cathode is covered with a corrosion resistive coating of lacquer, fulfilling the conditions of salt spray testing according to ASTM B117-49T and PNX41-002.





ZP1400

(18504)

(MX147)

GEIGER-MÜLLER TUBEEnd window halogen quenched β and γ radiation counter tube.**QUICK REFERENCE DATA**

Effective range	10^{-4} to 1 R/h
Plateau	400 to 600 V
Recommended supply voltage	500 V
Cr Fe cathode	250 mg/cm ²
Mica window (\varnothing 9 mm)	2,0 to 3,0 mg/cm ²

DIMENSIONS AND CONNECTIONS

Dimensions in mm

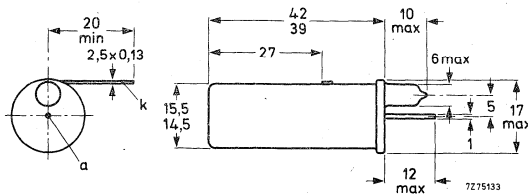
Use only anode connector
supplied with tube.**WINDOW**

Thickness	2,0 to 3,0	mg/cm ²
Effective diameter	9	mm
Material	mica	

CATHODE

Thickness	250	mg/cm ²
Effective length	39	mm
Material	chrome - iron, $\approx 28\%$ Cr, $\approx 72\%$ Fe	

FILLING

neon, argon, halogen

CAPACITANCE

Anode to cathode	2	pF
------------------	---	----

OPERATING CHARACTERISTICS ($t_{amb} = 25\text{ }^{\circ}\text{C}$) measured in circuit of Fig. 1

Starting voltage	\leq	325	V
Recommended supply voltage		500	V
Plateau		400 to 600	V
Plateau slope	\leq	0,04	%/V
Background, shielded with 50 mm Pb and 3 mm Al lining, at $V_b = 500\text{ V}$	\leq	10	count/min
Dead time at $V_b = 500\text{ V}$	max.	90	μs

LIMITING VALUES (Absolute max. rating system)

Anode resistor	min.	4,7	$\text{M}\Omega$
Anode voltage	max.	600	V
Ambient temperature	min.	-50	$^{\circ}\text{C}$
for continuous operation	max.	+75	$^{\circ}\text{C}$
	max.	+50	$^{\circ}\text{C}$

LIFE EXPECTANCY

Life expectancy at $t_{amb} = 25\text{ }^{\circ}\text{C}$, count rate 1200 c/s 5×10^{10} count

MEASURING CIRCUIT

$R_1 = 10\text{ M}\Omega$

$R_2 = 220\text{ k}\Omega$

$C_1 = 1\text{ pF}$

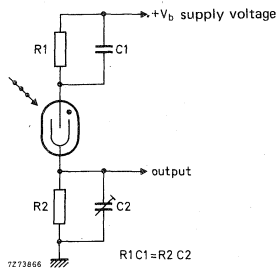
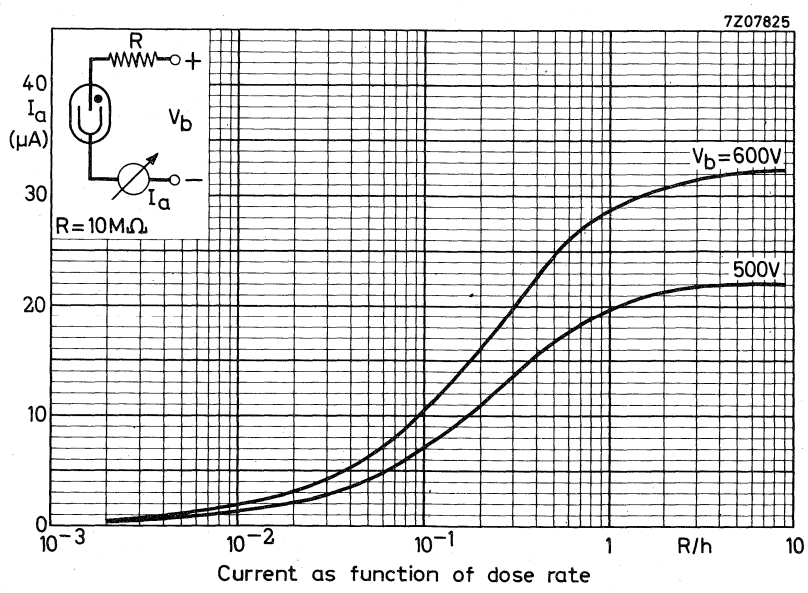
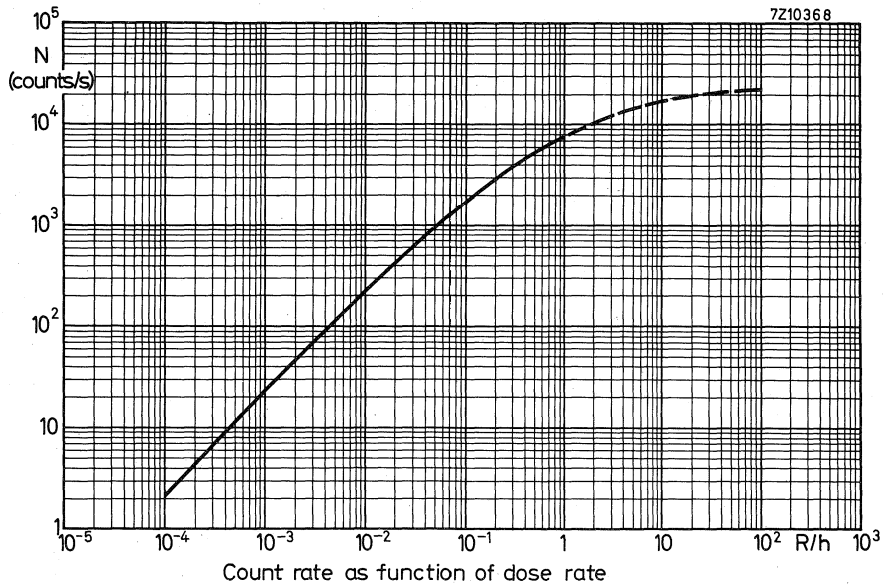
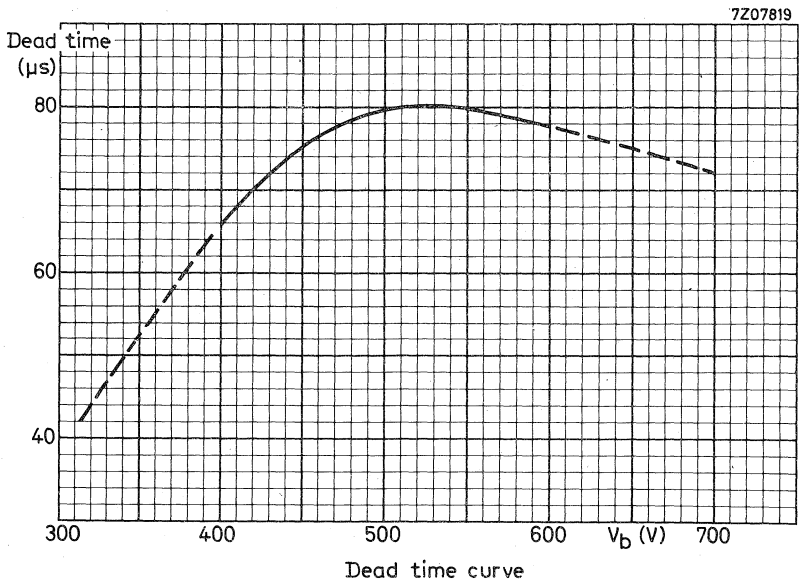
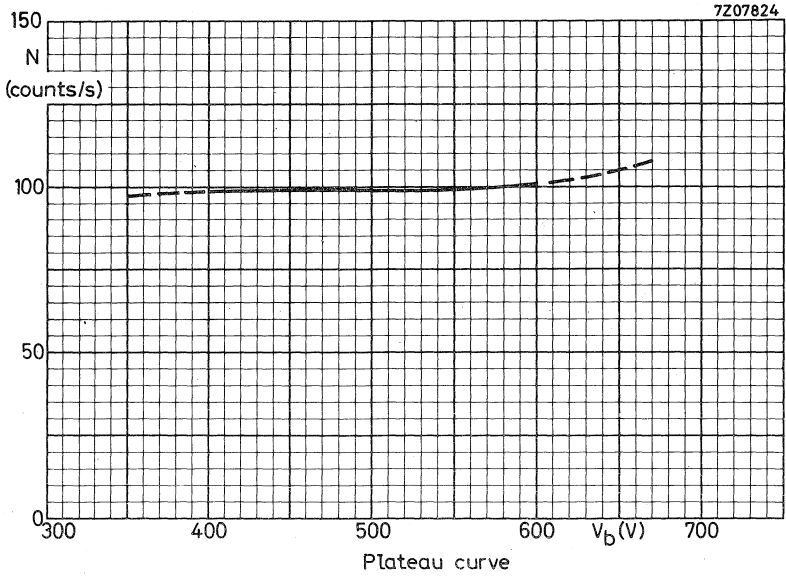

Fig. 1





GEIGER-MÜLLER TUBE

End window halogen quenched α , β and γ radiation counter tube.

QUICK REFERENCE DATA	
Effective range	10^{-4} to 3 R/h
Plateau	450 to 700 V
Recommended operating voltage	575 V
Cr Fe cathode	910 mg/cm^2
Mica window (\varnothing 19,8 mm)	1,5 to 2,0 mg/cm^2

DIMENSIONS AND CONNECTIONS

Dimensions in mm

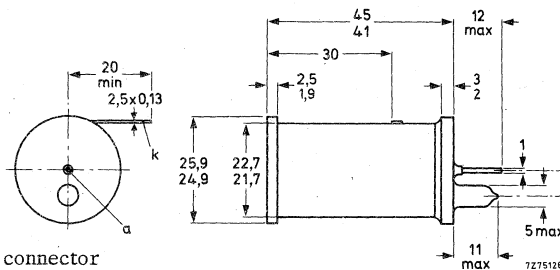

Use only anode connector supplied with tube.

WINDOW

Thickness	1,5 to 2,0	mg/cm^2
Effective diameter	19,8	mm
Material	mica	

CATHODE

Thickness	910	mg/cm^2
Effective length	37	mm
Material	chrome-iron, $\approx 28\%$ Cr, $\approx 72\%$ Fe	

FILLING

neon, argon, halogen

CAPACITANCE

Anode to cathode	2,5	pF
------------------	-----	----

OPERATING CHARACTERISTICS ($t_{amb} = 25\text{ }^{\circ}\text{C}$) measured in circuit of Fig. 1

Starting voltage	\leq	350	V
Recommended supply voltage		575	V
Plateau	450 to	700	V
Plateau slope	\leq	0,02	%/V
Background, shielded with 50 mm Pb and 3 mm Al lining, at $V_b = 575\text{ V}$	\leq	15	count/min
Dead time at $V_b = 500\text{ V}$	\leq	175	μs

LIMITING VALUES (Absolute max. rating system)

Anode resistor	min.	2,2	$\text{M}\Omega$
Anode voltage	max.	700	V
Ambient temperature	min.	-50	$^{\circ}\text{C}$
	max.	+75	$^{\circ}\text{C}$
for continuous operation	max.	+50	$^{\circ}\text{C}$

LIFE EXPECTANCY

Life expectancy at $t_{amb} = 25\text{ }^{\circ}\text{C}$, count rate 500 c/s 5×10^{10} count

MEASURING CIRCUIT

R = 10 $\text{M}\Omega$

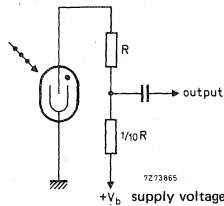
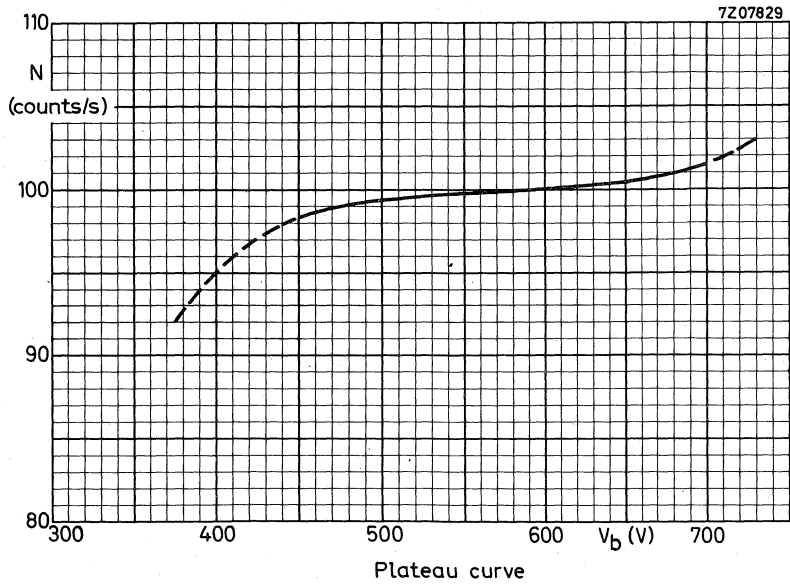
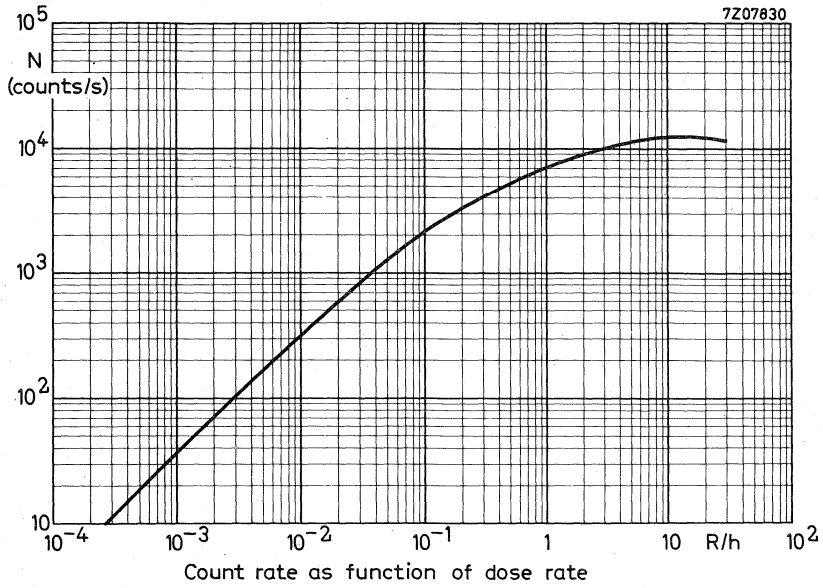
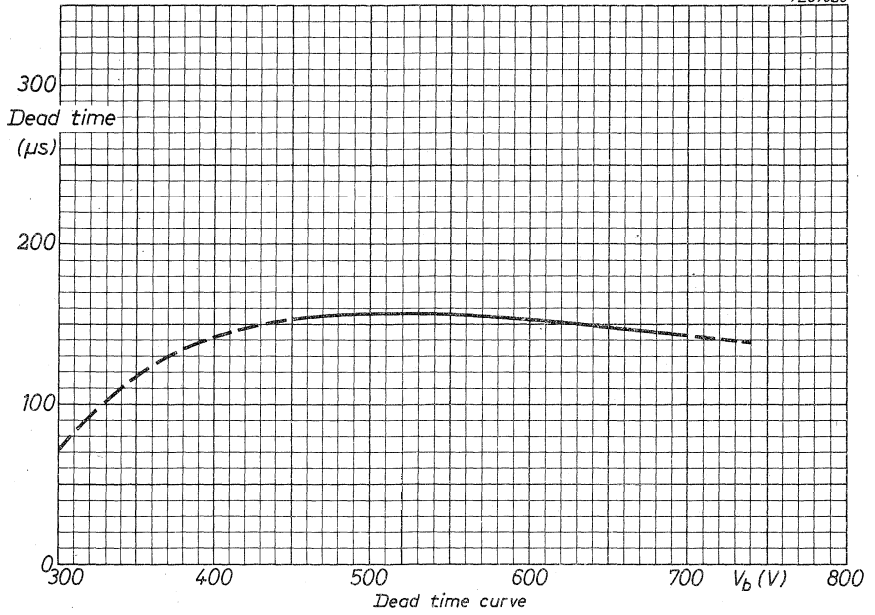

Fig. 1





GEIGER-MÜLLER TUBE

End window halogen quenched α , β , and γ radiation counter tube.

QUICK REFERENCE DATA	
Effective range	10^{-4} to 2 R/h
Plateau	450 to 700 V
Recommended supply voltage	575 V
Cr Fe cathode	980 mg/cm ²
Mica window (\emptyset 27,8 mm)	1,5 to 2,0 mg/cm ²

DIMENSIONS AND CONNECTIONS

Dimensions in mm

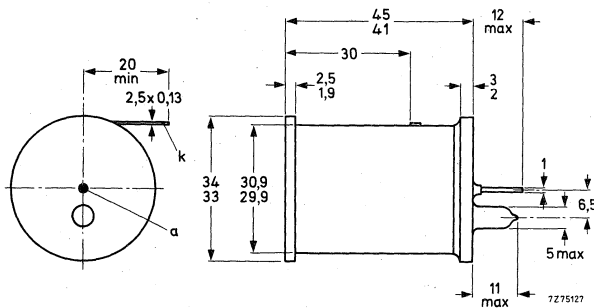

Use only anode connector supplied with tube.

WINDOW

Thickness	1,5 to 2,0	mg/cm ²
Effective diameter	27,8	mm
Material	mica	

CATHODE

Thickness	980	mg/cm ²
Effective length	37	mm
Material	chrome-iron, $\approx 28\%$ Cr, $\approx 72\%$ Fe	

FILLING

neon, argon, halogen

CAPACITANCE

Anode to cathode 3,5 pF

OPERATING CHARACTERISTICS ($t_{amb} = 25\text{ }^{\circ}\text{C}$) measured in circuit of Fig. 1

Starting voltage	≤	375	V
Recommended supply voltage		575	V
Plateau	450 to	700	V
Plateau slope	≤	0,035	%/V
Background, shielded with 50 mm Pb and 3 mm Al lining, at $V_b = 575\text{ V}$	≤	25	count/min
Dead time at $V_b = 575\text{ V}$	≤	190	μs

LIMITING VALUES (Absolute max. rating system)

Anode resistor	min.	2,2	MΩ
Anode voltage	max.	700	V
Ambient temperature	min.	-50	°C
	max.	+75	°C
for continuous operation	max.	+50	°C

LIFE EXPECTANCY

Life expectancy at $t_{amb} = 25\text{ }^{\circ}\text{C}$, count rate 2200 c/s 5×10^{10} count

MEASURING CIRCUIT

$R_1 = 10\text{ M}\Omega$

$R_2 = 220\text{ k}\Omega$

$C_1 = 1\text{ pF}$

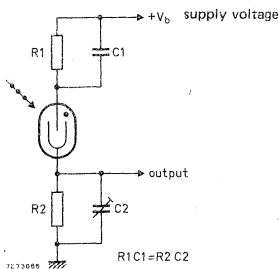
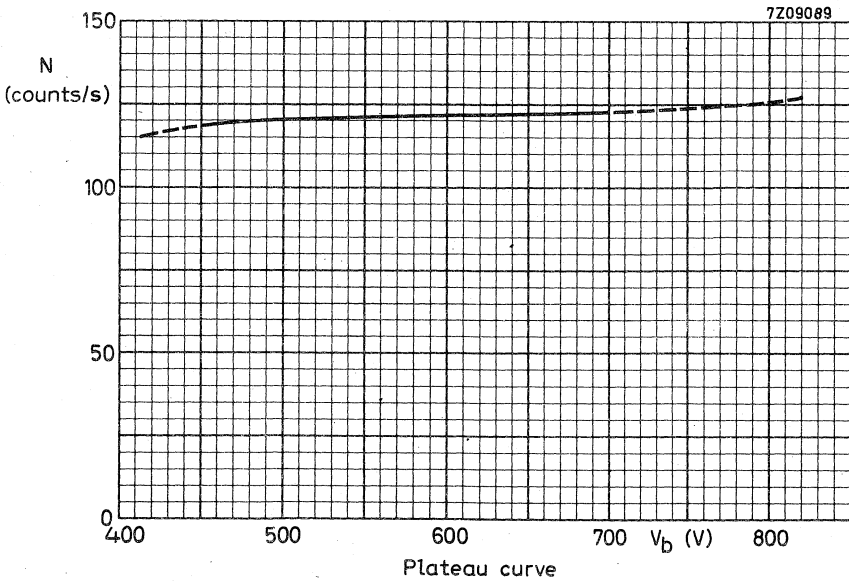
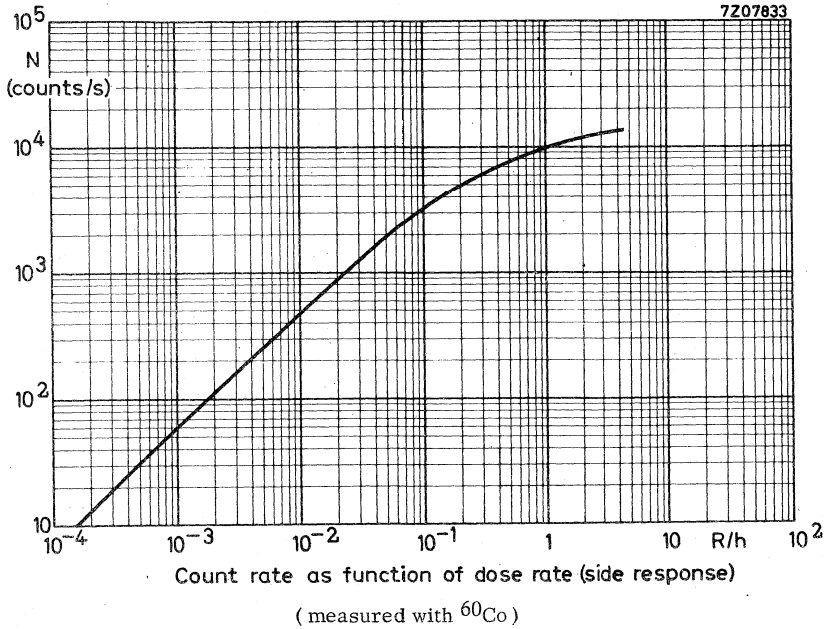
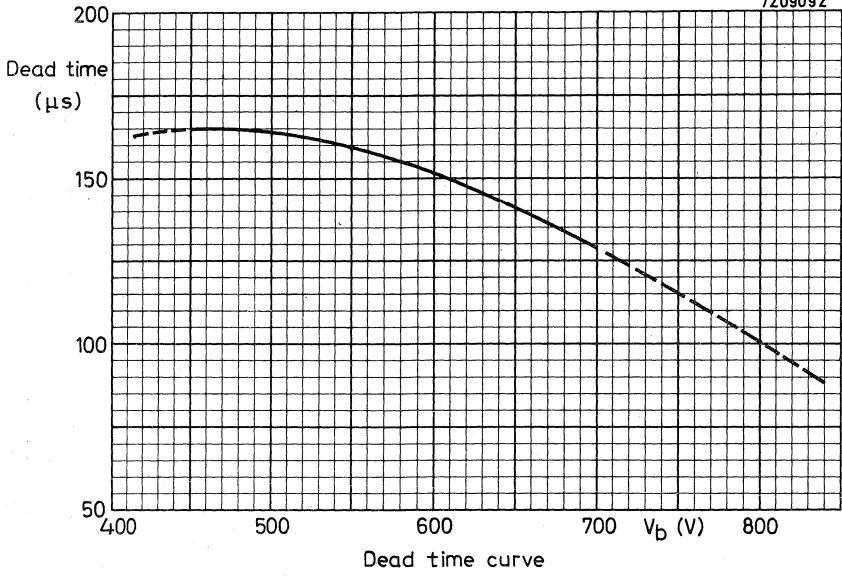

Fig. 1





GEIGER-MÜLLER TUBE

End window halogen quenched α and β radiation counter tube.

QUICK REFERENCE DATA	
Effective range	10^{-2} to 10 R/h
Plateau	500 to 700 V
Recommended supply voltage	600 V
Cr Fe cathode	910 mg/cm^2
Mica window (\emptyset 19,8 mm)	1,5 to 2,0 mg/cm^2

DIMENSIONS AND CONNECTIONS

Dimensions in mm

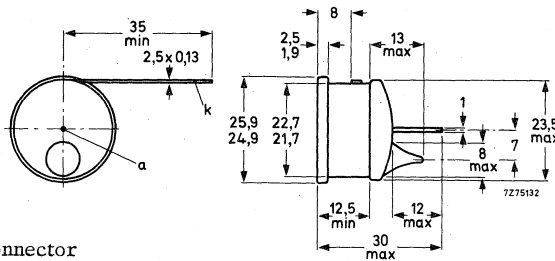

Use only anode connector supplied with tube.

WINDOW

Thickness	1,5 to 2,0 mg/cm^2
Effective diameter	19,8 mm
Material	mica

CATHODE

Thickness	910 mg/cm^2
Effective length	13 mm
Material	chrome-iron, $\approx 28\%$ Cr, $\approx 72\%$ Fe

FILLING

neon, argon, halogen

CAPACITANCE

Anode to cathode	1 pF
------------------	------

OPERATING CHARACTERISTICS ($t_{amb} = 25\text{ }^{\circ}\text{C}$) measured in circuit of Fig.1

Starting voltage	\leq	350	V
Recommended supply voltage		600	V
Plateau		500 to 700	V
Plateau slope	\leq	0,09	%/V
Background, shielded with 50 mm Pb and 3 mm Al lining, at $V_b = 600\text{ V}$	\leq	8	count/min
Dead time at $V_b = 600\text{ V}$	\leq	65	μs

LIMITING VALUES (Absolute max. rating system)

Anode resistor	min.	2,2	M Ω
Anode voltage	max.	700	V
Ambient temperature	max.	+75	$^{\circ}\text{C}$
for continuous operation	min.	-50	$^{\circ}\text{C}$
	max.	+50	$^{\circ}\text{C}$

LIFE EXPECTANCY

Life expectancy at $t_{amb} = 25\text{ }^{\circ}\text{C}$, count rate 4300 c/s 5×10^{10} counts

MEASURING CIRCUIT

$R_1 = 4,7\text{ M}\Omega$

$R_2 = 100\text{ k}\Omega$

$C_1 = 1\text{ pF}$

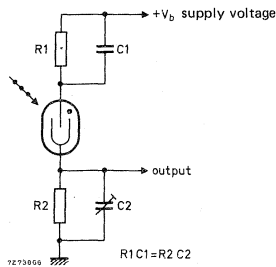
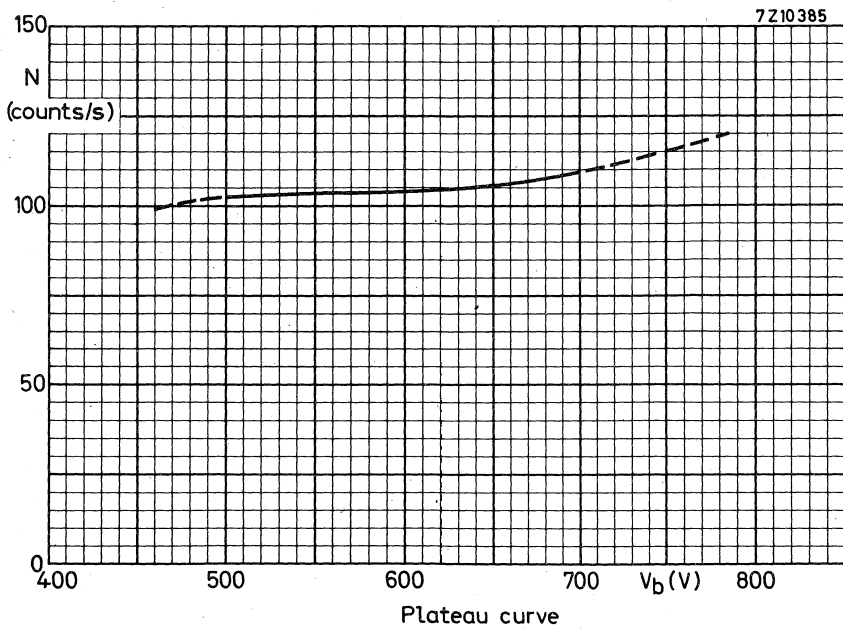
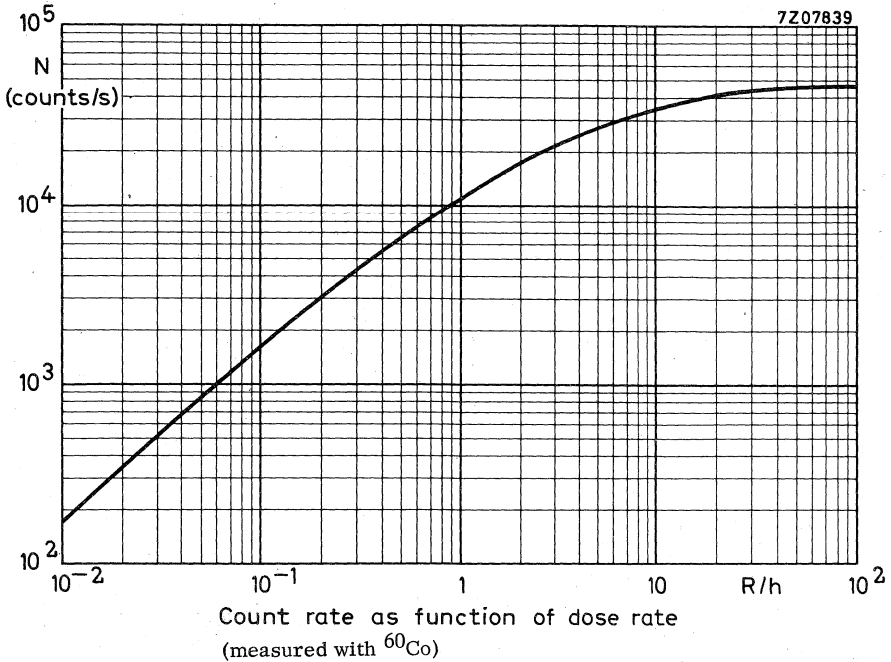
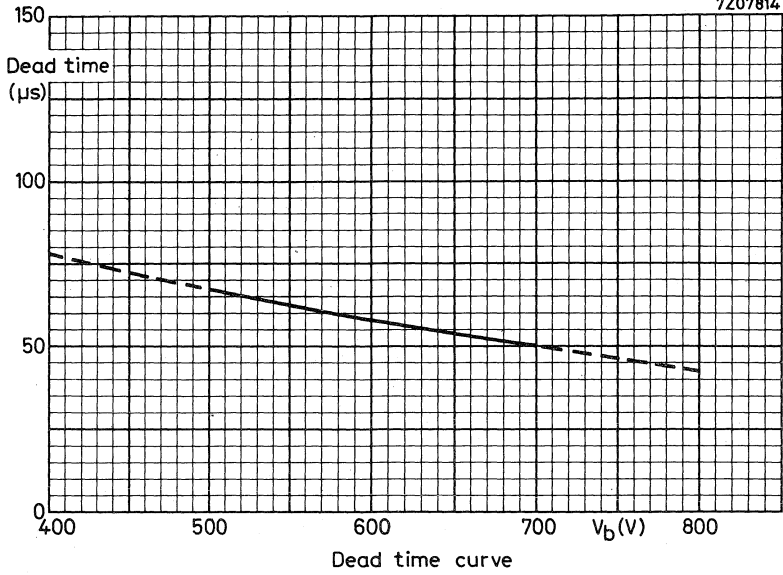

Fig. 1





GEIGER-MÜLLER TUBE

End window halogen quenched α and β radiation counter tube for low level measurements in combination with a guard counter (e. g. type ZP1700).

QUICK REFERENCE DATA	
Effective range	10^{-2} to 10 R/h
Plateau	500 to 700 V
Recommended supply voltage	600 V
Cr Fe cathode	910 mg/cm ²
Mica window (\emptyset 19,8 mm)	1,5 to 2,0 mg/cm ²

DIMENSIONS AND CONNECTIONS

Dimensions in mm

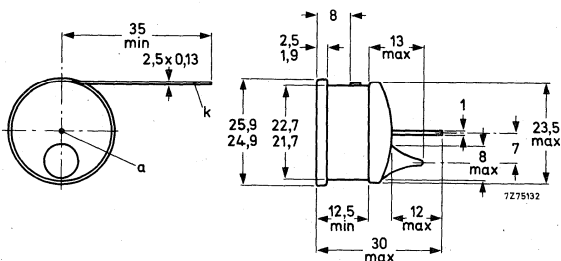

Use only anode connector supplied with tube.

WINDOW

Thickness	1,5 to 2,0 mg/cm ²
Effective diameter	19,8 mm
Material	mica

CATHODE

Thickness	910 mg/cm ²
Effective length	13 mm
Material	chrome-iron, \approx 28% Cr, \approx 72% Fe

FILLING

neon, argon, halogen

CAPACITANCE

Anode to cathode	1 pF
------------------	------

OPERATING CHARACTERISTICS ($t_{amb} = 25\text{ }^{\circ}\text{C}$) measured in circuit of Fig. 1

Starting voltage	\leq	350	V
Recommended supply voltage		600	V
Plateau		500 to 700	V
Plateau slope	\leq	0,09	%/V
Background, shielded with 50 mm Pb and 3 mm Al lining, at $V_b = 600\text{ V}$	max.	5	count/min
Background in anticoincidence circuit with guard counter ZP1700 shielded with 100 mm Fe and 30 mm Pb, Fe outside, at $V_b = 600\text{ V}$	max.	1,2	count/min
Dead time at $V_b = 600\text{ V}$	max.	65	μs

LIMITING VALUES (Absolute max. rating system)

Anode resistor	min.	2,2	$\text{M}\Omega$
Anode voltage	max.	700	V
Ambient temperature	min.	-50	$^{\circ}\text{C}$
	max.	+75	$^{\circ}\text{C}$
for continuous operation	max.	+50	$^{\circ}\text{C}$

LIFE EXPECTANCY

Life expectancy at $t_{amb} = 25\text{ }^{\circ}\text{C}$, count rate 4300 c/s 5×10^{10} count

MEASURING CIRCUIT

$R_1 = 4,7\text{ M}\Omega$

$R_2 = 100\text{ k}\Omega$

$C_1 = 1\text{ pF}$

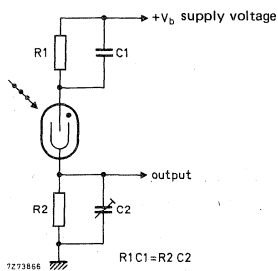
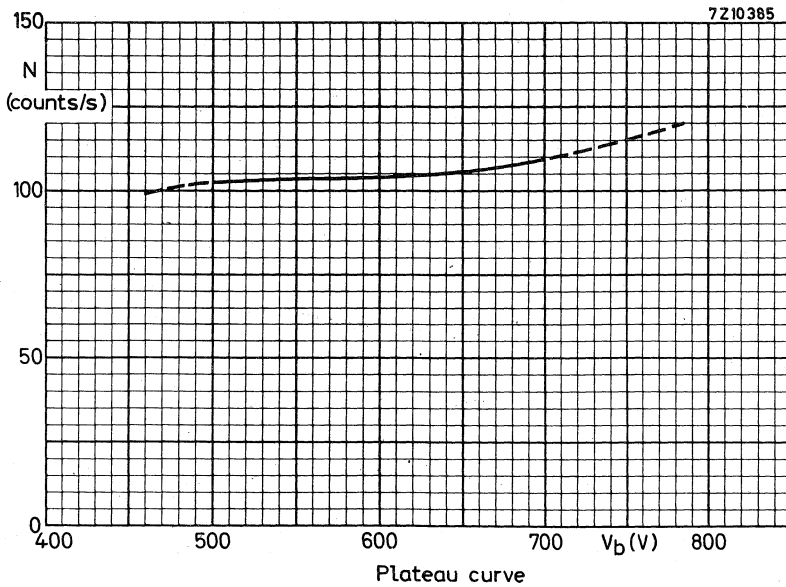
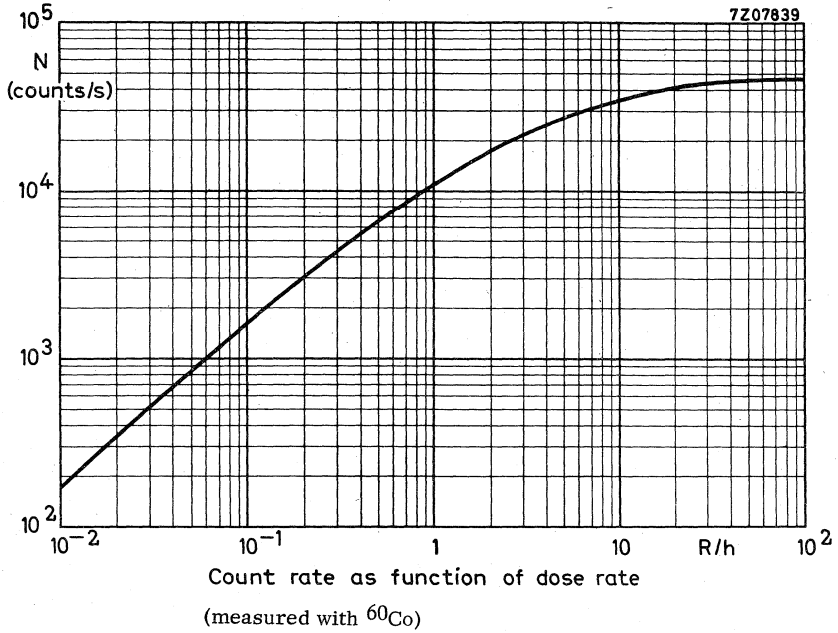
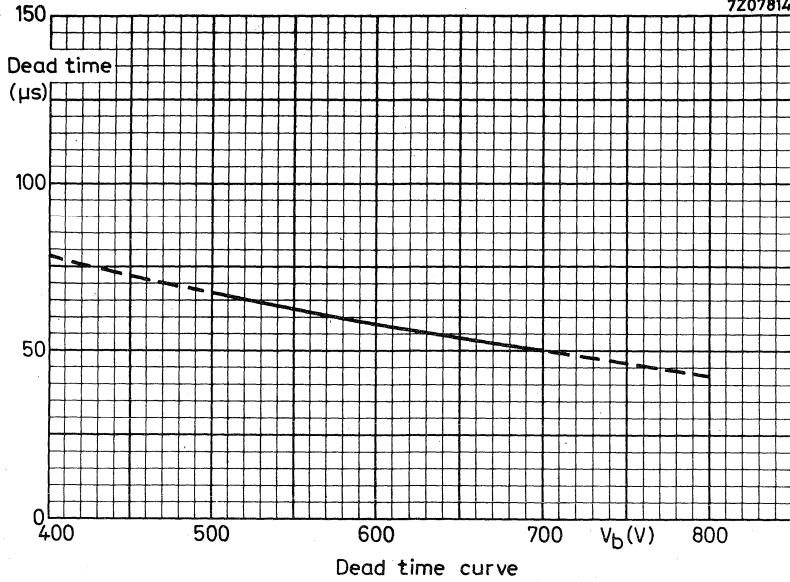

Fig. 1





GEIGER-MÜLLER TUBE

End window halogen quenched α and β radiation counter tube for low level measurements.

QUICK REFERENCE DATA	
Effective range	10^{-4} to 3 R/h
Plateau	500 to 750 V
Recommended supply voltage	600 V
Cr Fe cathode	980 mg/cm^2
Mica window (ϕ 27,8 mm)	1,5 to 2,0 mg/cm^2

DIMENSIONS AND CONNECTIONS

Dimensions in mm

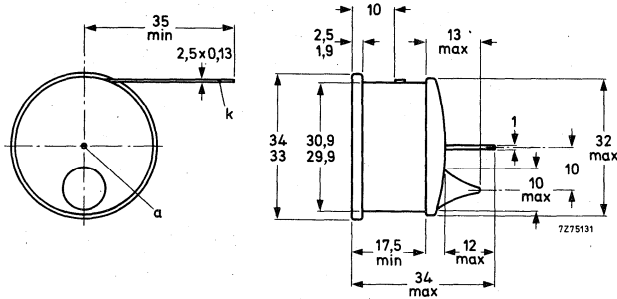

Use only anode connector supplied with tube.

WINDOW

Thickness	1,5 to 2,0 mg/cm^2
Effective diameter	27,8 mm
Material	mica

CATHODE

Thickness	980 mg/cm^2
Effective length	18 mm
Material	chrome-iron, $\approx 28\%$ Cr, $\approx 72\%$ Fe

FILLING

neon, argon, halogen

CAPACITANCE

Anode to cathode	1,4 pF
------------------	--------

OPERATING CHARACTERISTICS ($t_{amb} = 25\text{ }^{\circ}\text{C}$) measured in circuit of Fig. 1

Starting voltage	\leq	375	V
Recommended supply voltage		600	V
Plateau		500 to 750	V
Plateau slope	\leq	0,07	%/V
Background, shielded with 50 mm Pb and 3 mm Al lining, at $V_b = 600\text{ V}$	\leq	18	count/min
Dead time at $V_b = 600\text{ V}$	\leq	60	μs

LIMITING VALUES (Absolute max. rating system)

Anode resistor	min.	4,7	$\text{M}\Omega$
Anode voltage	max.	750	V
Ambient temperature for continuous operation	max.	+75	$^{\circ}\text{C}$
	min.	-50	$^{\circ}\text{C}$
	max.	+50	$^{\circ}\text{C}$

LIFE EXPECTANCY

Life expectancy at $t_{amb} = 25\text{ }^{\circ}\text{C}$, count rate 3200 c/s 5×10^{10} count

MEASURING CIRCUIT

- $R_1 = 10\text{ M}\Omega$
- $R_2 = 220\text{ k}\Omega$
- $C_1 = 1\text{ pF}$

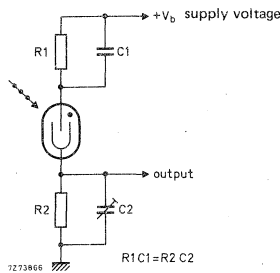
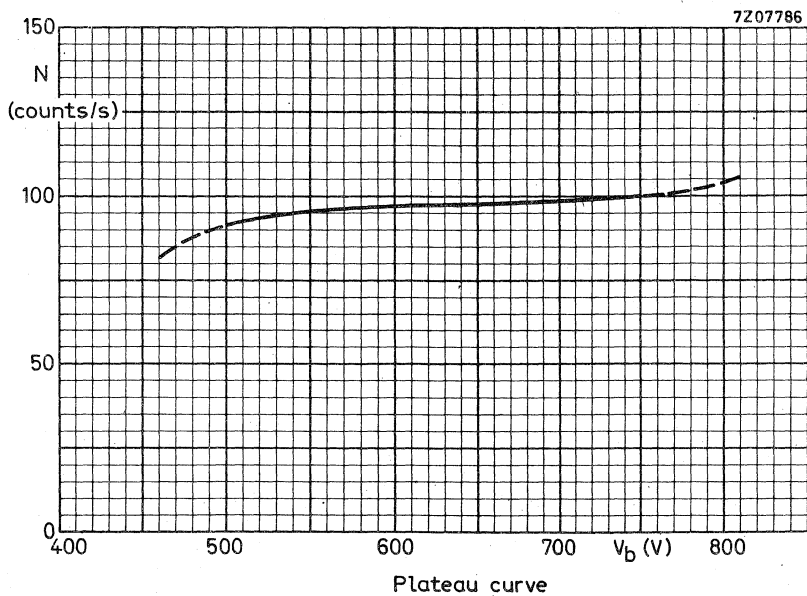
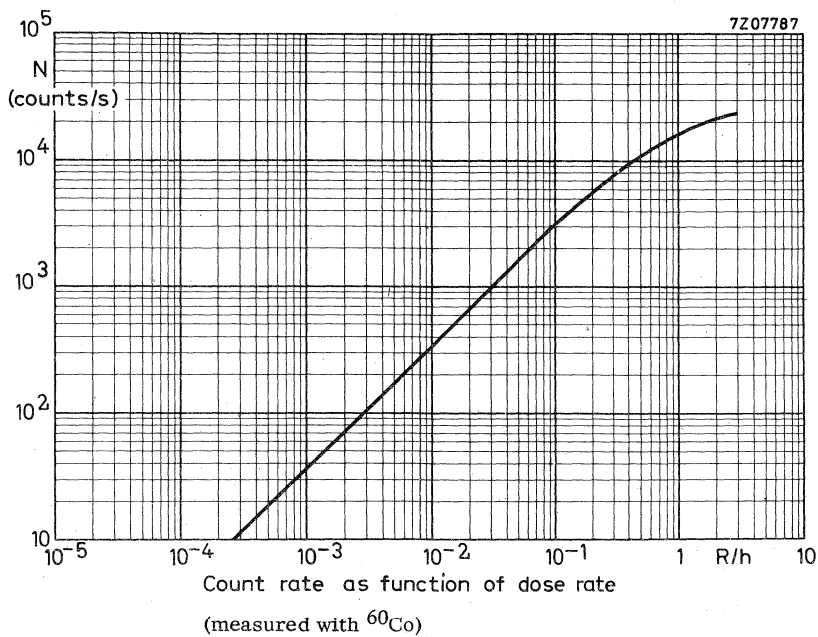
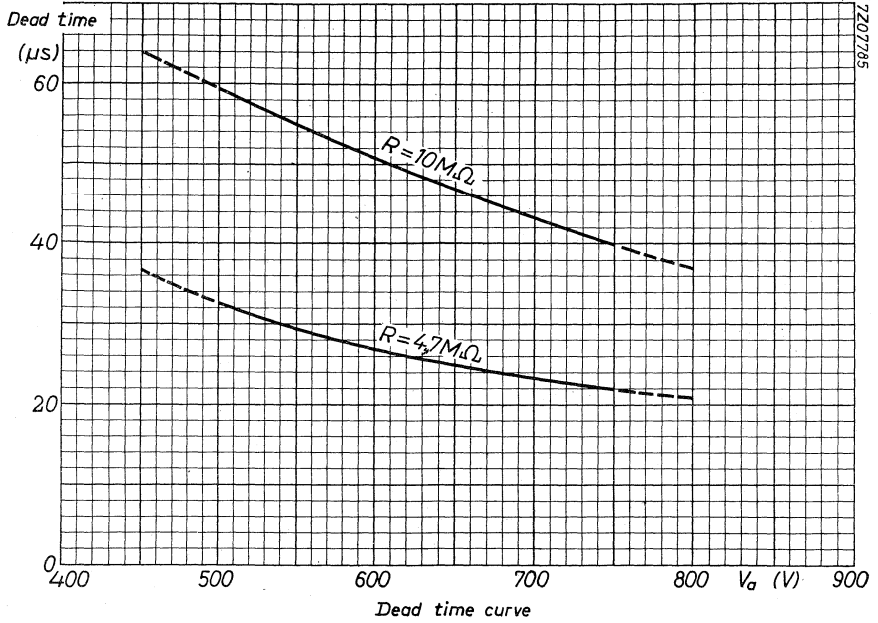

Fig. 1





720795



GEIGER-MÜLLER TUBE

End window halogen quenched α and β radiation counter tube, for low level measurements in combination with a guard counter (e. g. type ZP1700).

QUICK REFERENCE DATA	
Effective range	10^{-4} to 3 R/h
Plateau	500 to 750 V
Recommended supply voltage	600 V
Cr Fe cathode	980 mg/cm^2
Mica window (\varnothing 27, 8 mm)	1, 5 to 2, 0 mg/cm^2

DIMENSIONS AND CONNECTIONS

Dimensions in mm

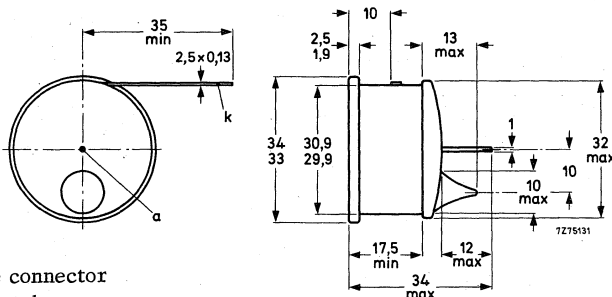

Use only anode connector supplied with tube.

WINDOW

Thickness	1, 5 to 2, 0	mg/cm^2
Effective diameter	27, 8	mm
Material		mica

CATHODE

Thickness	980	mg/cm^2
Effective length	18	mm
Material	chrome-iron, $\approx 28\%$ Cr, $\approx 72\%$ Fe	

FILLING

neon, argon, halogen

CAPACITANCE

Anode to cathode	1, 4	pF
------------------	------	----

OPERATING CHARACTERISTICS ($t_{amb} = 25\text{ }^{\circ}\text{C}$) measured in circuit of Fig. 1

Starting voltage	\leq	375	V
Recommended supply voltage		600	V
Plateau		500 to 750	V
Plateau slope	\leq	0,07	%/V
Background, shielded with 50 mm Pb and 3 mm Al lining, at $V_b = 600\text{ V}$	\leq	9	count/min
Background in anticoincidence circuit with guard counter ZP1700 shielded with 100 mm Fe and 30 mm Pb, Fe outside, at $V_b = 600\text{ V}$	\leq	2	count/min
Dead time at $V_b = 600\text{ V}$	\leq	60	μs

LIMITING VALUES (Absolute max. rating system)

Anode resistor	min.	4,7	$\text{M}\Omega$
Anode voltage	max.	750	V
Ambient temperature	min.	-50	$^{\circ}\text{C}$
for continuous operation	max.	+75	$^{\circ}\text{C}$
	max.	+50	$^{\circ}\text{C}$

LIFE EXPECTANCY

Life expectancy at $t_{amb} = 25\text{ }^{\circ}\text{C}$, count rate 3200 c/s 5×10^{10} count

MEASURING CIRCUIT

$R_1 = 10\text{ M}\Omega$

$R_2 = 220\text{ k}\Omega$

$C_1 = 1\text{ pF}$

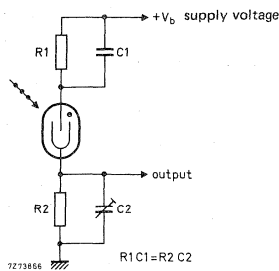
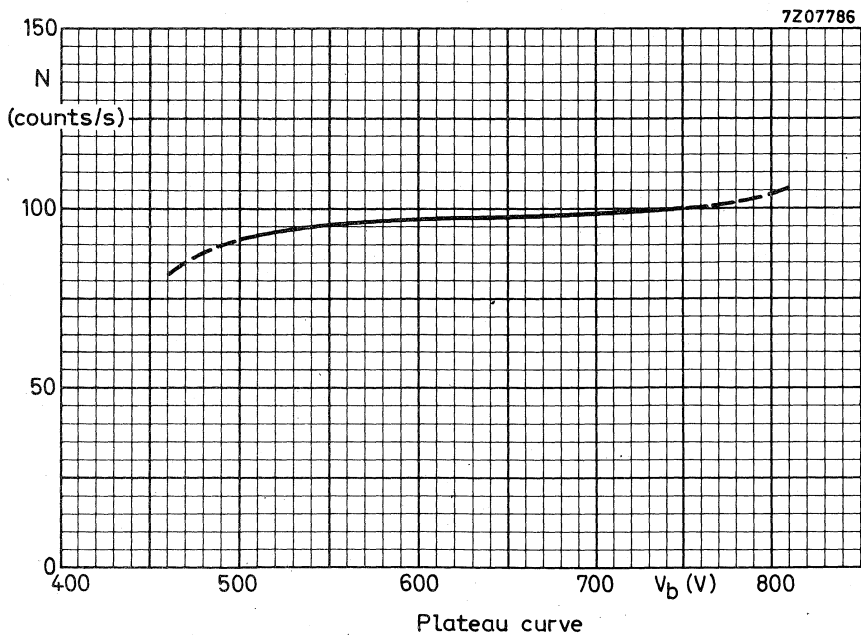
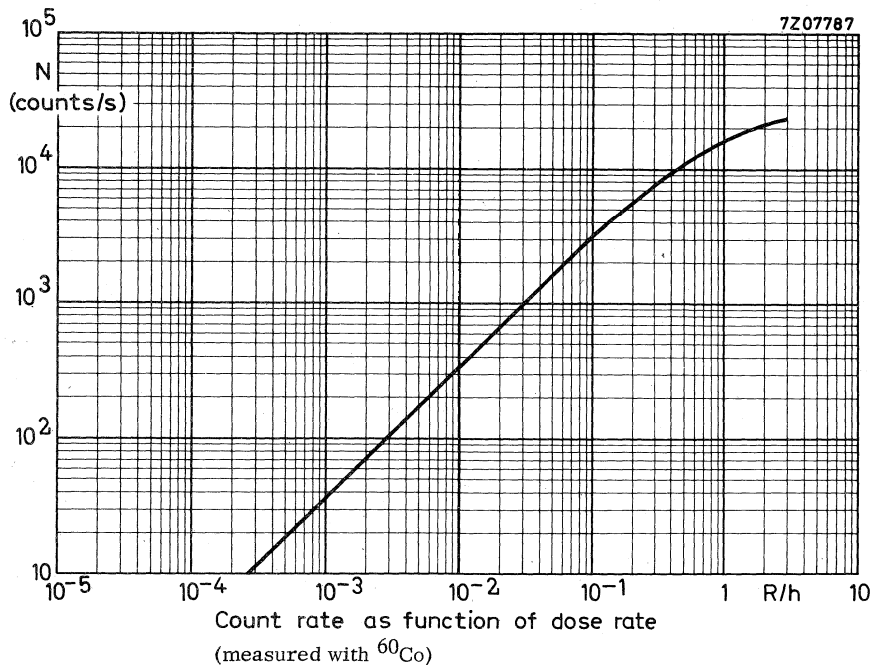
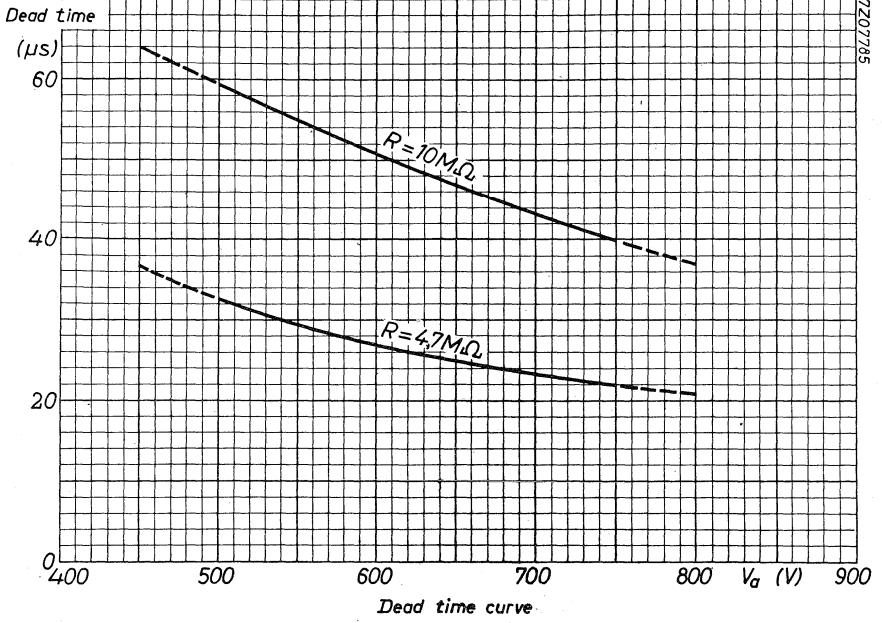

Fig. 1





720785



GEIGER-MÜLLER TUBE

End window halogen quenched β radiation counter tube.

QUICK REFERENCE DATA		
Effective range	3×10^{-2} to 100	mR/h
Plateau	700 to 1100	V
Recommended supply voltage	900	V
Cr Fe cathode	950	mg/cm ²
Mica window (\emptyset 51 mm)	3,5 to 4,0	mg/cm ²

DIMENSIONS AND CONNECTIONS

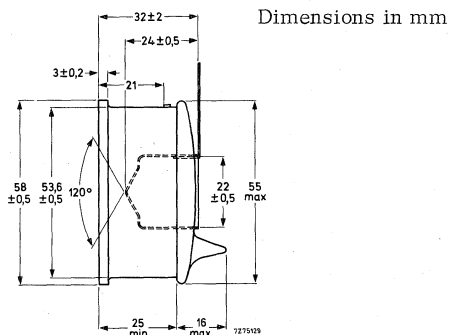
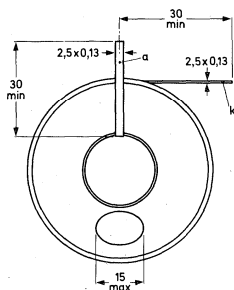

Dimensions in mm

WINDOW

Thickness	3,5 to 4	mg/cm ²
Effective diameter	51	mm
Material	mica	

CATHODE

Thickness	950	mg/cm ²
Effective length	25	mm
Material	chrome-iron, $\approx 28\%$ Cr, $\approx 72\%$ Fe	

FILLING

neon, argon, halogen

CAPACITANCE

Anode to cathode	5	pF
------------------	---	----

OPERATING CHARACTERISTICS ($t_{amb} = 25\text{ }^{\circ}\text{C}$) measured in circuit of Fig. 1

Starting voltage	\leq	400	V
Recommended supply voltage		900	V
Plateau		700 to 1100	V
Plateau slope	\leq	0,04	%/V
Background, shielded with 50 mm Pb and 3 mm Al lining, at $V_b = 900\text{ V}$	\leq	45	count/min
Dead time at $V_b = 900\text{ V}$	\leq	45	μs

LIMITING VALUES (Absolute max. rating system)

Anode resistor	min.	3,9	$\text{M}\Omega$	
Anode voltage	max.	1100	V	
Ambient temperature	min.	-50	$^{\circ}\text{C}$	
for continuous operation	max.	+75	$^{\circ}\text{C}$	
		max.	+50	$^{\circ}\text{C}$

LIFE EXPECTANCY

Life expectancy at $t_{amb} = 25\text{ }^{\circ}\text{C}$, count rate 2500 c/s	5×10^{10}	count
---	--------------------	-------

MEASURING CIRCUIT

$R = 4,7\text{ M}\Omega$

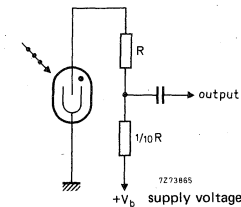
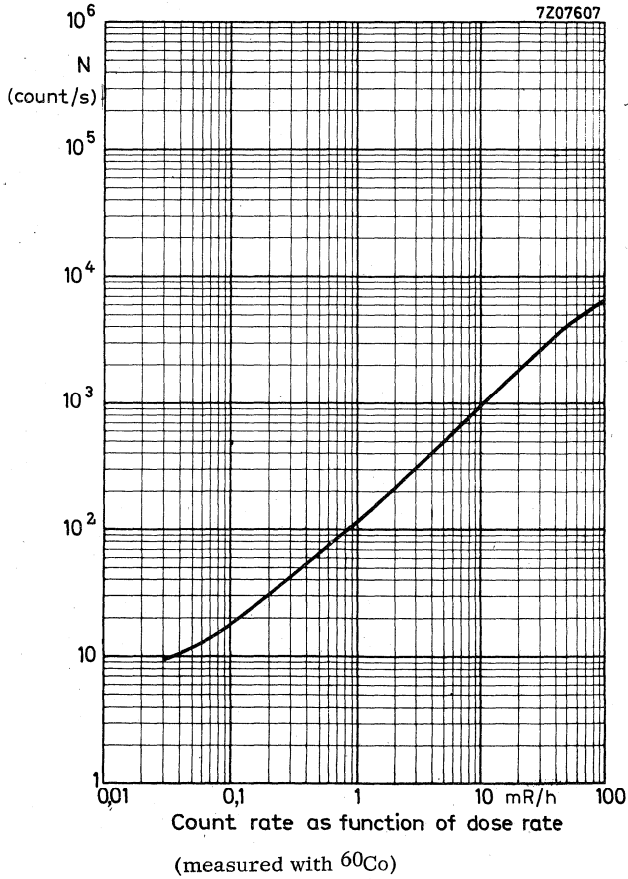
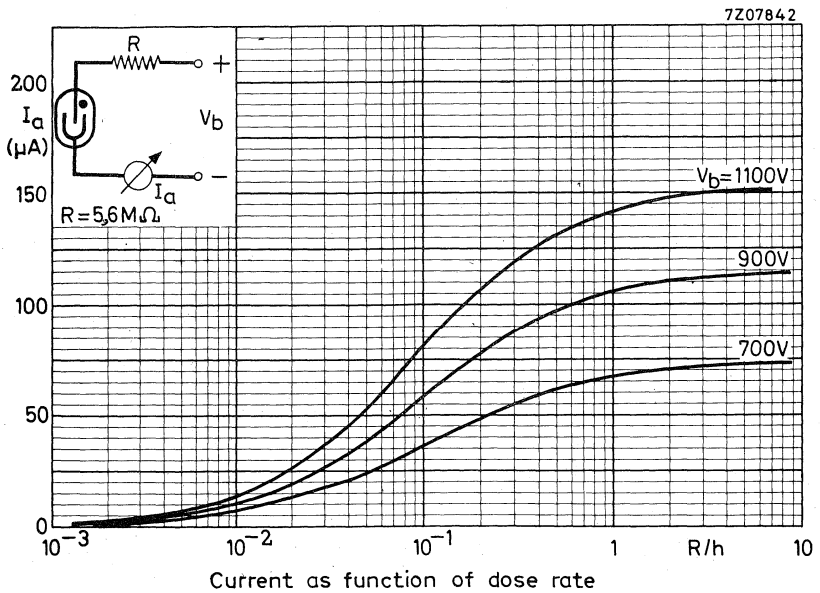
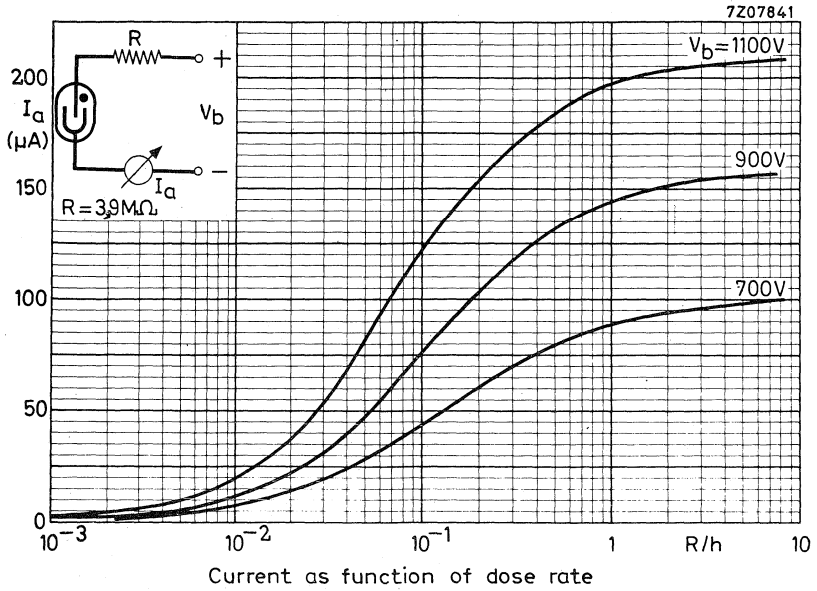
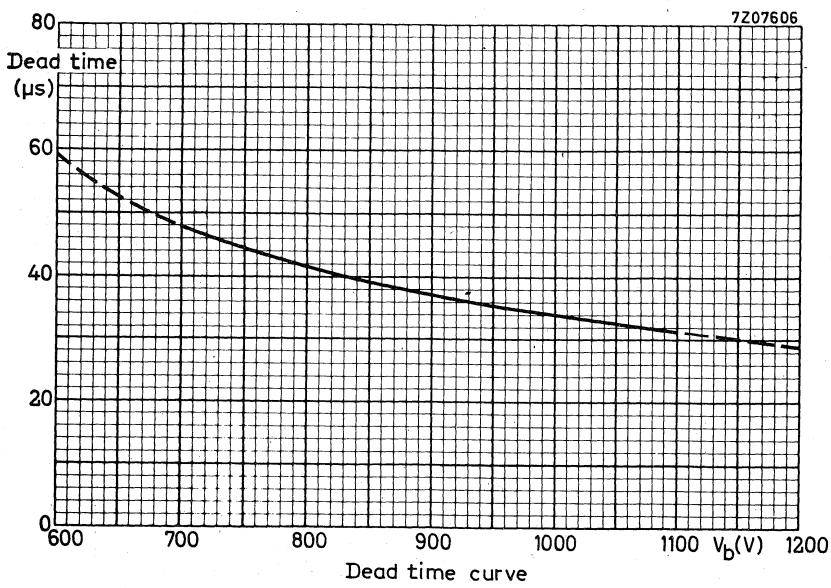
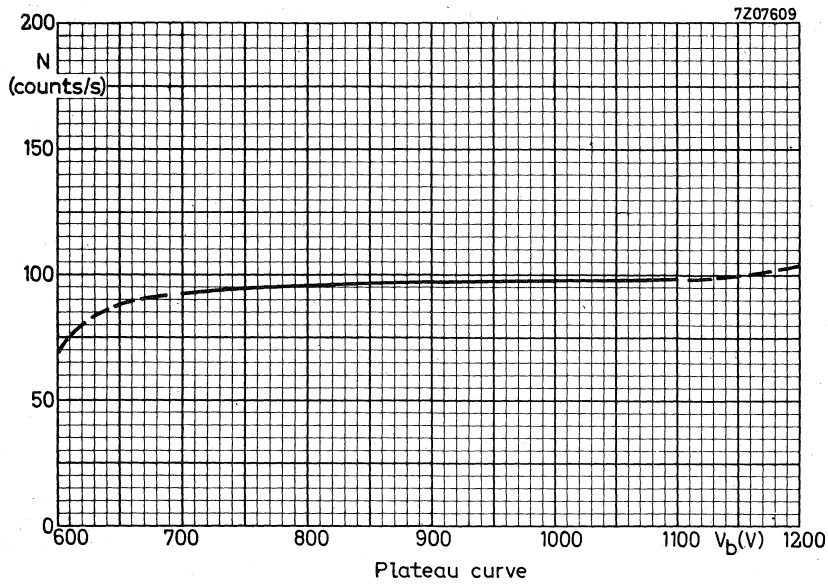

Fig. 1







GEIGER-MÜLLER TUBE

Halogen quenched liquid sample tube.

QUICK REFERENCE DATA		
Plateau	400 to 500	V
Recommended supply voltage	450	V
Sample volume	9 to 10	ml

DIMENSIONS AND CONNECTIONS

Dimensions in mm

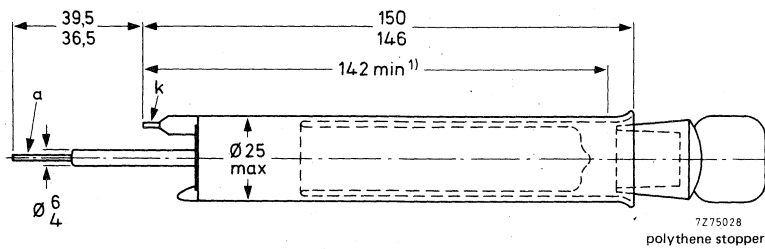

Connections for use with mercury pools

1) $\varnothing 25$ over this length.

CATHODE

Spiral diameter (mean) 12,5 mm
 Effective length 60 mm
 Material chrome-iron, $\approx 28\%$ Cr, $\approx 72\%$ Fe

FILLING

neon, argon, halogen

CAPACITANCE

Anode to cathode 2,5 pF

OPERATING CHARACTERISTICS ($t_{amb} = 25\text{ }^{\circ}\text{C}$) measured in circuit of Fig. 1.

Starting voltage	\leq	350	V
Recommended supply voltage		450	V
Plateau		400 to 500	V
Plateau slope	\leq	0,15	%/V
Background shielded with 50 mm Pb and 3 mm Al lining, at $V_b = 450\text{ V}$	\leq	50	count/mi
Dead time at $V_b = 450\text{ V}$	\leq	100	μs

LIMITING VALUES (Absolute max. rating system)

Anode resistor	min.	2,7	$\text{M}\Omega$
Anode voltage	max.	500	V
Ambient temperature	max.	+75	$^{\circ}\text{C}$
	min.	-50	$^{\circ}\text{C}$

LIQUID CAPACITY

To top of inner tube	9 to 10	ml
----------------------	---------	----

MEASURING CIRCUIT

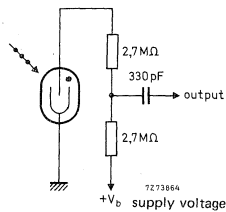
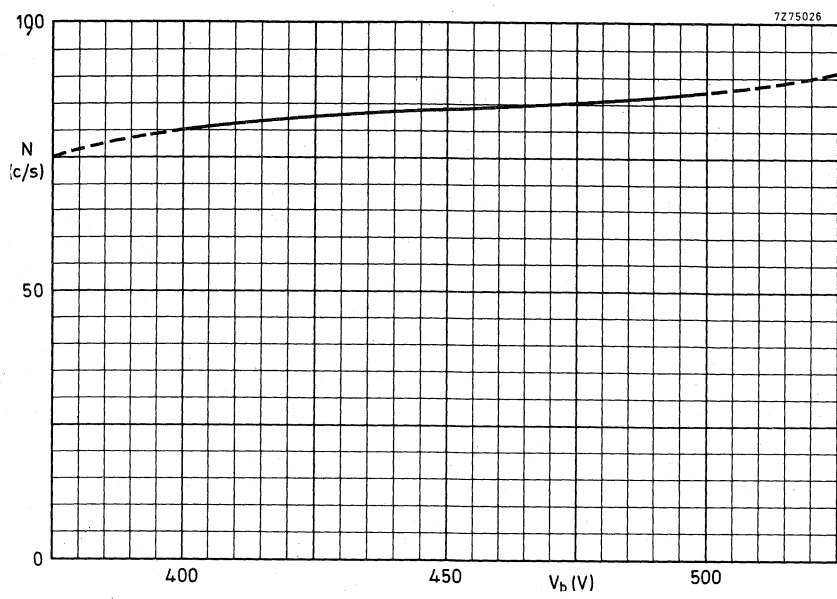
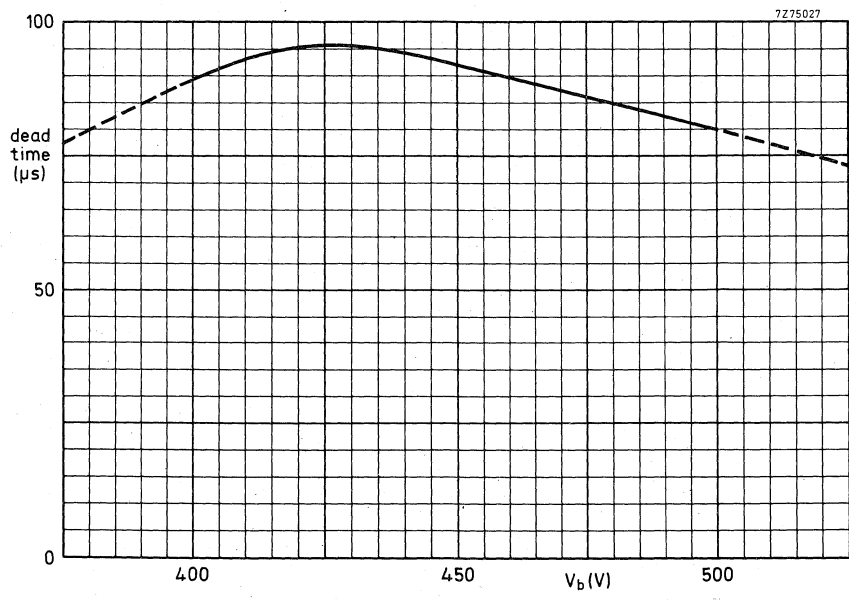

Fig. 1



Plateau curve



Dead time curve



X-RAY COUNTER TUBE

End window halogen quenched X-ray counter tube.

QUICK REFERENCE DATA		
Energy range	2,5 to 20	keV
Wavelength	0,06 to 0,5	nm
Plateau	1600 to 2000	V
Recommended supply voltage	1800	V
Cr Fe cathode	910	mg/cm ²
Mica window (∅ 19,8 mm)	2,5 to 3,5	mg/cm ²

DIMENSIONS AND CONNECTIONS

Dimensions in mm

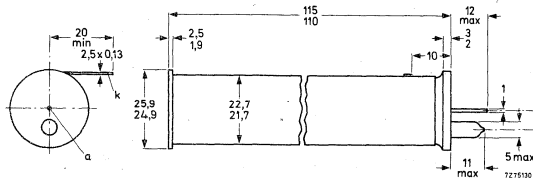

Use only anode connector
supplied with tube.

WINDOW

Thickness	2,5 to 3,5	mg/cm ²
Effective diameter	19,8	mm
Material	mica	

CATHODE

Thickness	910	mg/cm ²
Effective length	107	mm
Material	chrome-iron, ≈ 28% Cr, ≈ 72% Fe	

FILLING

Gas pressure	argon, halogen 62,7 kPa (47 cm Hg)	
--------------	---------------------------------------	--

Caution: Air transport in airtight boxes only

CAPACITANCE

Anode to cathode	2,8	pF
------------------	-----	----

OPERATING CHARACTERISTICS ($t_{amb} = 25\text{ }^{\circ}\text{C}$) measured in circuit of Fig. 1

Starting voltage	\leq	1450	V
Recommended supply voltage		1800	V
Plateau		1600 to 2000	V
Plateau slope	\leq	0, 04	%/V
Background, shielded with 50 mm Pb and 3 mm Al lining, at $V_b = 1800\text{ V}$	\leq	25	count/min
Dead time at $V_b = 1800\text{ V}$	\leq	110	μs

LIMITING VALUES (Absolute max. rating system)

Anode resistor	min.	5	$\text{M}\Omega$
Anode voltage	max.	2000	V
Ambient temperature	min.	0	$^{\circ}\text{C}$
	max.	+75	$^{\circ}\text{C}$
for continuous operation	max.	+50	$^{\circ}\text{C}$

LIFE EXPECTANCY

Life expectancy at $t_{amb} = 25\text{ }^{\circ}\text{C}$, count rate 900 c/s 10^{10} count

MEASURING CIRCUIT

R = 5 $\text{M}\Omega$

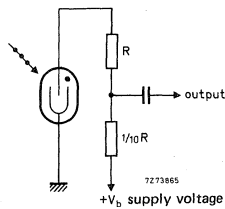
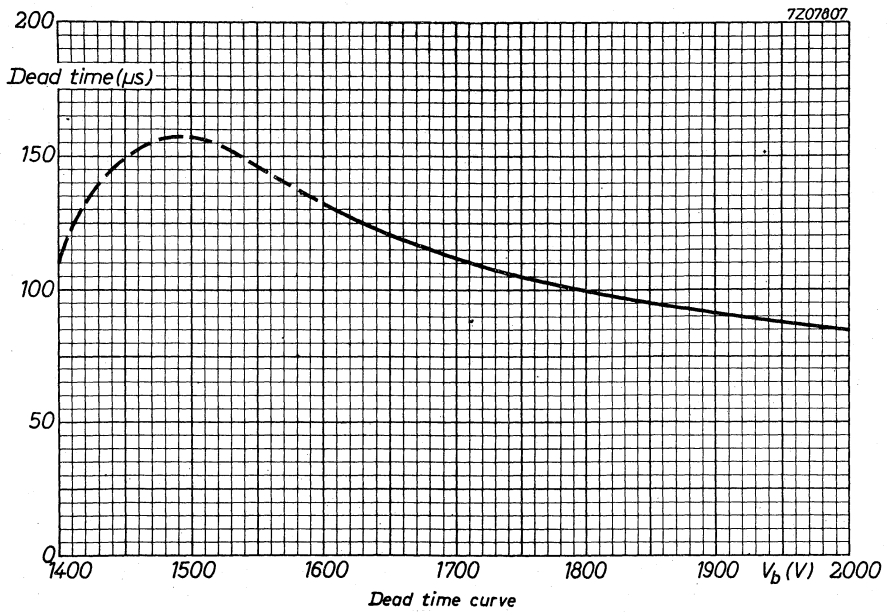
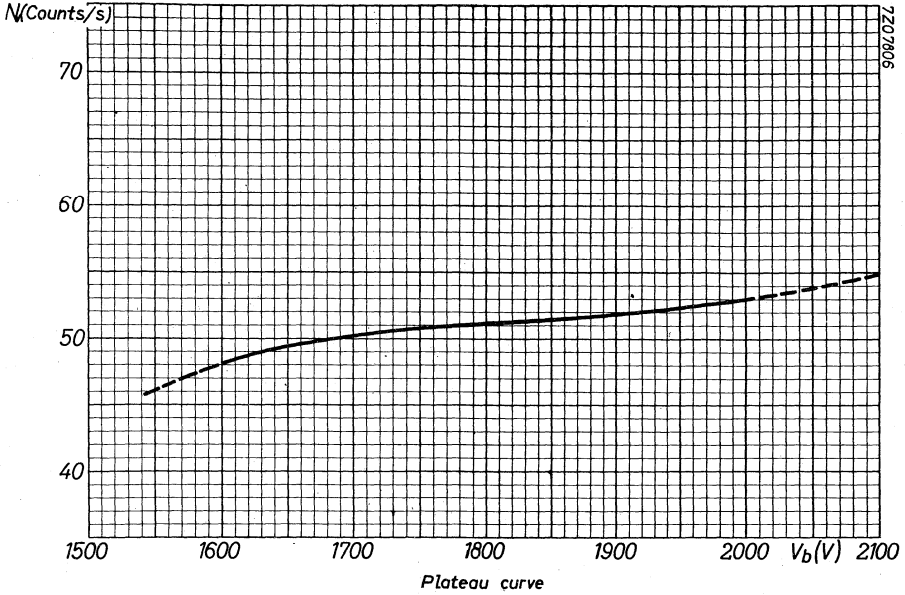

Fig. 1



X-RAY COUNTER TUBE

Side window organic quenched X-ray counter tube

QUICK REFERENCE DATA	
Energy range	2,5 to 40 KeV
Wavelength	0,03 to 0,5 nm
Operating voltage range	1500 to 1800 V
Mica window (7 x 18 mm)	2,0 to 2,5 mg/cm ²

DIMENSIONS AND CONNECTIONS

Dimensions in mm

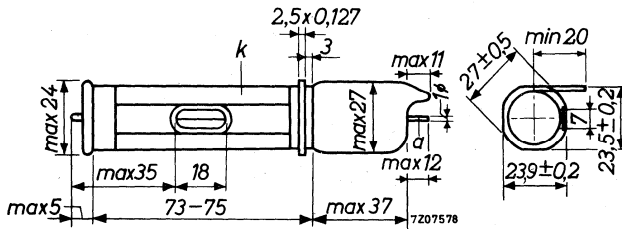

Use only anode connector supplied with tube.

WINDOW

Thickness	2,0 to 2,5	mg/cm ²
Dimensions	7 x 18	mm ²
Material	mica	

CATHODE

Effective length	67	mm
Material	chrome-iron, $\approx 28\%$ Cr, $\approx 72\%$ Fe	

FILLING

xenon, organic vapour
xenon pressure 25 cm Hg

CAPACITANCE

Anode to cathode	2	pF
------------------	---	----

OPERATING CHARACTERISTICS ($t_{amb} = 25\text{ }^{\circ}\text{C}$) measured in circuit of Fig. 1

Operating voltage		1500 to 1850	V ¹⁾
Geiger threshold		min. 1900	V
Operating voltage for pulse amplitude $V_p = 1\text{ mV}$		1460 to 1540	V ²⁾
Operating voltage for pulse amplitude $V_p = 10\text{ mV}$		1690 to 1770	V ²⁾
Energy resolution (See page 3)	$\Delta P/P$	max. 22	% ²⁾³⁾
Integrated background for pulses 50% of the pulse amplitude P (unshielded), at $V_p = 1550\text{ V}$		15	count/min. ²⁾

LIMITING VALUES (Absolute max. rating system)

Anode voltage	max.	1850	V
Ambient temperature	min.	-20	$^{\circ}\text{C}$
	max.	+50	$^{\circ}\text{C}$

MEASURING CIRCUIT

$R_1 = 2, 2\text{ k}\Omega$

$R_2 = 0, 1\text{ M}\Omega$

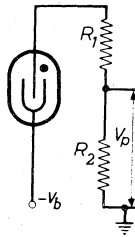
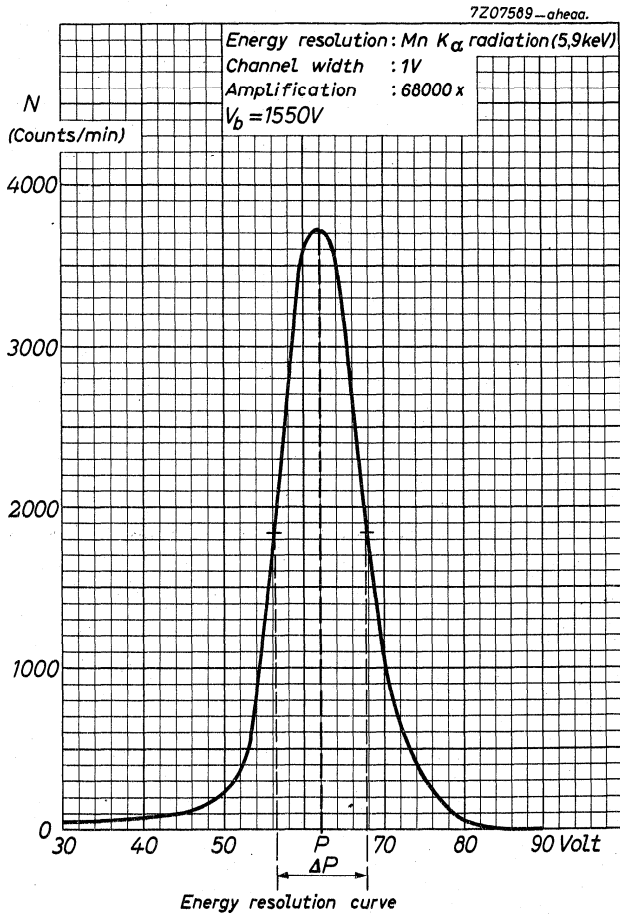

Fig. 1

- 1) To obtain max. tube life V_b should be kept as low as possible.
- 2) For Mn K α radiation (5, 9 keV).
- 3) P = average pulse amplitude, ΔP = width of the pulse amplitude distribution at half of the max. value.



COSMIC RAY GUARD COUNTER TUBE

Halogen quenched cosmic ray guard counter tube for low background measurements in combination with β counter (e.g. type ZP1440 or ZP1450) in an anticoincidence circuit. It can also be used in combination with a gas-flow counter.

QUICK REFERENCE DATA	
Effective range	4×10^{-2} to 10 mR/h
Plateau	800 to 1200 V
Recommended supply voltage	1000 V
Cr Fe cathode	760 mg/cm ²

DIMENSIONS AND CONNECTIONS

Dimensions in mm

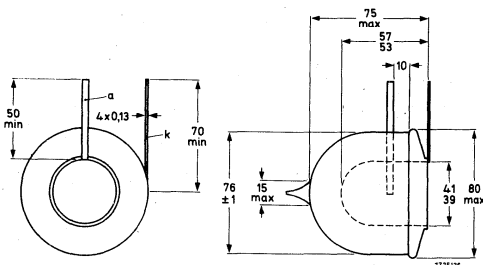

CATHODE AND ANODE

Thickness

760 mg/cm²

Material

chrome-iron, $\approx 28\%$ Cr, $\approx 72\%$ Fe

FILLING

neon, argon, halogen

CAPACITANCE

Anode to cathode

8 pF

OPERATING CHARACTERISTICS $(t_{amb} = 25\text{ }^{\circ}\text{C})$ measured in circuit of Fig. 1

Starting voltage	\leq	650	V
Recommended supply voltage		1000	V
Plateau (at 50 c/s)		800 to 1200	V
Plateau slope (at 50 c/s)	\leq	0, 03	%/V
Background, shielded with 100 mm Fe and 30 mm Pb, Fe outside, at $V_b = 1000$ V	\leq	70	count/min
Dead time (at 50 c/s)	\leq	1	ms

LIMITING VALUES (Absolute max. rating system)

Anode resistor	min.	10	$\text{M}\Omega$
Anode voltage	max.	1200	V
Ambient temperature	min.	-50	$^{\circ}\text{C}$
for continuous operation	max.	+75	$^{\circ}\text{C}$
	max.	+50	$^{\circ}\text{C}$

LIFE EXPECTANCY

Life expectancy at $t_{amb} = 25\text{ }^{\circ}\text{C}$, count rate 1300 c/s	5×10^{10}	count
---	--------------------	-------

MEASURING CIRCUIT

For use as guard counter tube in anticoincidence circuits in combination with ZP1440 or ZP1450; recommended circuit see Fig. 2.

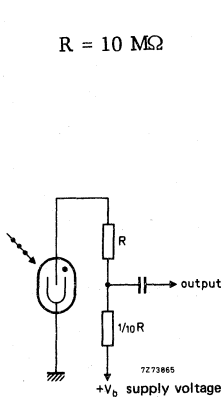

Fig. 1

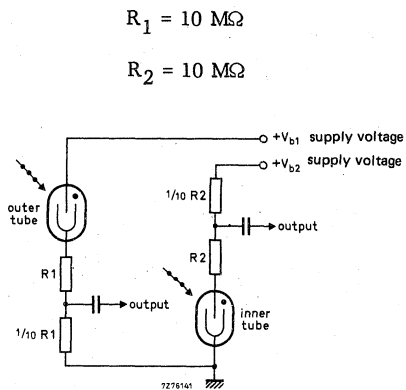
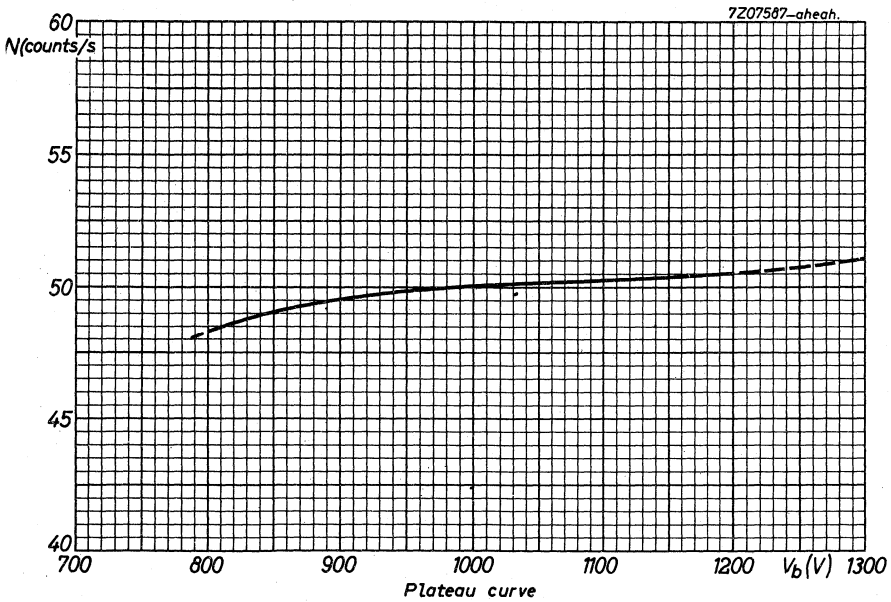
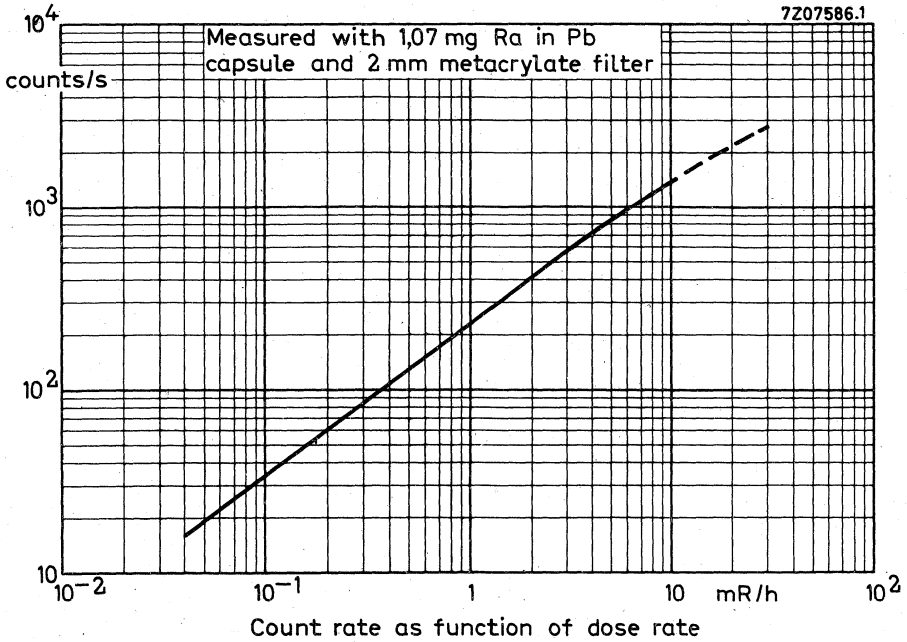

Fig. 2



OBSOLETE TYPE

18553

(MX178)

GEIGER-MÜLLER TUBE

Halogen quenched beta ($>0,3$ MeV) and gamma radiation counter tube.

Replacement type (ZP1330).



Neutron tubes



NEUTRON TUBES

Sealed-off accelerating tubes generating 14 MeV neutrons on the basis of the $^3\text{H} (d, n) ^4\text{He}$ reaction.

The gas filling (a mixture of deuterium and tritium) is controlled by a pressure regulator. Deuterium and tritium ions emitted from a Penning ion source are accelerated towards a titanium/tritium target bringing about the $^3\text{H} (d, n) ^4\text{He}$ reaction whilst replenishing the tritium in the target. This guarantees a lasting and even target performance throughout tube life.

Examples of application:

- Activation analysis
- Radio biology
- Radio chemistry
- Neutron radiography
- Neutron dosimetry
- Investigation of neutron collimation
- Investigation of shielding
- Investigation of radiation damage
- Isotope production
- Fast reactor control
- Nuclear physics research
- Solid state physics
- Education
- Nuclear safeguards

NEUTRON TUBE TYPES	Minimum output (n/s)	
	continuous	pulse
18600R	1×10^8	-
18601C	1×10^8	5×10^9
18603C	1×10^8	5×10^9

Further particulars on request.

Semiconductor radiation detectors



SEMICONDUCTOR RADIATION DETECTORS

<i>Energy range</i>	<i>Application</i>	<i>Technology</i>		<i>Basic types</i>
10 keV to 10 MeV γ	High resolution gamma and X-ray spectrometry in nuclear science (e.g. decay schemes) and industrial research (e.g. activation analysis)	Lithium drifted germanium		APY21 to APY27
	40 keV to 10 MeV γ	coaxial	double open-ended	
		40 keV to 10 MeV γ		single open-ended
	40 keV to 10 MeV γ	Virtually 4 π measurement of gamma radiation and X-rays in: <ul style="list-style-type: none"> ● absolute activity measurement ● source calibration ● sum peak coincidence experiments 		well-type
40 keV to 8 MeV γ	Gamma and high energy X-ray spectrometry	planar		APY16 to APY19
< 80 MeV α < 1,5 MeV β	Spectrometry of alpha and low energy beta radiation, particles and fission products. Particle identification systems	Silicon surface barrier		
		partially depleted	circular	BPY51 to BPY57 BPW25
	annular		BPY58 to BPY59	
	< 75 MeV α < 1,2 MeV β	Spectrometry of alpha and low energy beta radiation, particles and fission products. Particle identification systems	totally depleted	circular
annular				BPY88, BPY89

For detailed information please ask for the "Product Survey Semiconductor Radiation Detectors".

INDEX OF TYPE NUMBERS

type	section	type	section	type	section
APY 16 to 19	S. R. D.	MX 163	see ZP1300	18503	see ZP1200
APY 21 to 27	S. R. D.	MX 164	see ZP1320	18504	see ZP1400
APY 41 to 49	S. R. D.	MX 166	see ZP1451	18507	see ZP1600
APY 56 to 59	S. R. D.	MX 166/01	see ZP1450	18509	see ZP1310
B310 series	C. E. M.	MX 167/01	see ZP1460	18511	see ZP1610
B312 series	C. E. M.	MX 169	see ZP1430	18515	see ZP1441
B318 series	C. E. M.	MX 177	see ZP1330	18515/01	see ZP1440
B330 series	C. E. M.	MX 178	see 18533	18518	see ZP1700
B410 series	C. E. M.	MX 189	see ZP1311	18520	see ZP1210
B413 series	C. E. M.	ZP 1200	G. M. T.	18526	see ZP1430
B419 series	C. E. M.	ZP 1210	G. M. T.	18529	see ZP1300
BPW25	S. R. D.	ZP 1220	G. M. T.	18536	see ZP1451
BPY 51 to 59	S. R. D.	ZP 1300	G. M. T.	18536/01	see ZP1450
BPY 81 to 89	S. R. D.	ZP 1310	G. M. T.	18545	see ZP1220
G25 - 25	C. E. M.	ZP 1311	G. M. T.	18546/01	see ZP1460
G25 - 50	C. E. M.	ZP 1320	G. M. T.	18550	see ZP1320
		ZP 1330	G. M. T.	18553	G. M. T.
G25 - 70	C. E. M.	ZP 1400	G. M. T.	18555	see ZP1330
MX 120/01	see ZP1210	ZP 1410	G. M. T.	18600R	N. T.
MX 124/01	see ZP1520	ZP 1420	G. M. T.	18601C	N. T.
MX 145	see ZP1220	ZP 1430	G. M. T.	18603	N. T.
MX 146	see ZP1200	ZP 1440	G. M. T.		
MX 147	see ZP1400	ZP 1441	G. M. T.		
MX 148	see ZP1410	ZP 1450	G. M. T.		
MX 150	see ZP1310	ZP 1451	G. M. T.		
MX 152	see ZP1441	ZP 1460	G. M. T.		
MX 152/01	see ZP1440	ZP 1520	G. M. T.		
MX 155	see ZP1700	ZP 1600	G. M. T.		
MX 159	see ZP1600	ZP 1610	G. M. T.		
MX 161	see ZP1610	ZP 1700	G. M. T.		

C. E. M. = Channel electron multipliers.
G. M. T. = Geiger-Müller tubes.

N. T. = Neutron tubes.
S. R. D. = Semiconductor radiation detectors.



Channel electron multipliers



Geiger-Mueller tubes



Neutron tubes



Semiconductor radiation detectors



Index

Argentina: FAPESA I.y.c., Av. Crovara 2550, Tablada, Prov. de BUENOS AIRES, Tel. 652-7438/7478.

Australia: PHILIPS INDUSTRIES HOLDINGS LTD., Elcoma Division, 67 Mars Road, LANE COVE, 2066, N.S.W., Tel. 42 1261.

Austria: ÖSTERREICHISCHE PHILIPS BAUELEMENTE Industrie G.m.b.H., Triester Str. 64, A-1101 WIEN, Tel. 62 91 11.

Belgium: M.B.L.E., 80, rue des Deux Gares, B-1070 BRUXELLES, Tel 523 00 00.

Brazil: IBRAPE, Caixa Postal 7383, Av. Paulista 2073-S/Loja, SAO PAULO, SP, Tel. 287-7144.

Canada: PHILIPS ELECTRONICS LTD., Electron Devices Div., 601 Milner Ave., SCARBOROUGH, Ontario, M1B 1M8, Tel. 292-5161.

Chile: PHILIPS CHILENA S.A., Av. Santa Maria 0760, SANTIAGO, Tel. 39-40 01.

Colombia: SADAPE S.A., P.O. Box 9805 Calle 13, No. 51 + 39, BOGOTA D.E. 1., Tel. 600 600.

Denmark: MINIWATT A/S, Emdrupvej 115A, DK-2400 KØBENHAVN NV., Tel. (01) 69 16 22.

Finland: OY PHILIPS AB, Elcoma Division, Kaivokatu 8, SF-00100 HELSINKI 10, Tel. 1 72 71.

France: R.T.C. LA RADIOTECHNIQUE-COMPELEC, 130 Avenue Ledru Rollin, F-75540 PARIS 11, Tel. 355-44-99.

Germany: VALVO, UB Bauelement der Philips G.m.b.H., Valvo Haus, Burchardstrasse 19, D-2 HAMBURG 1, Tel. (040) 3296-1.

Greece: PHILIPS S.A. HELLENIQUE, Elcoma Division, 52, Av. Syngrou, ATHENS, Tel. 915 311.

Hong Kong: PHILIPS HONG KONG LTD., Comp. Dept., Philips Ind. Bldg., Kung Yip St., K.C.T.L. 289, KWAI SHUNG, N.T. Tel. 12-24 51

India: PHILIPS INDIA LTD., Elcoma Div., Band Box House, 254-D, Dr. Annie Besant Rd., Prabhadevi, BOMBAY-25-DD, Tel. 457 311-5.

Indonesia: P. T. PHILIPS-RALIN ELECTRONICS, Elcoma Division, 'Timah' Building, Jl. Jen. Gatot Subroto, JAKARTA, Tel. 44 163.

Ireland: PHILIPS ELECTRICAL (IRELAND) LTD., Newstead, Clonskeagh, DUBLIN 14, Tel. 69 33 55.

Italy: PHILIPS S.P.A., Sezione Elcoma, Piazza IV Novembre 3, I-20124 MILANO, Tel. 2-6994.

Japan: NIHON PHILIPS CORP., Shuwa Shinagawa Bldg., 26-33 Takanawa 3-chome, Minato-ku, TOKYO (108), Tel. 448-5611.
(IC Products) SIGNETICS JAPAN, LTD., TOKYO, Tel. (03) 230-1521.

Korea: PHILIPS ELECTRONICS (KOREA) LTD., Philips House, 260-199 Itaewon-dong, Yongsan-ku, C.P.O. Box 3680, SEOUL, Tel. 44-4202.

Mexico: ELECTRONICA S.A. de C.V., Varsovia No. 36, MEXICO 6, D.F., Tel. 5-33-11-80.

Netherlands: PHILIPS NEDERLAND B.V., Afd. Elonco, Boschdijk 525, NL-4510 EINDHOVEN, Tel. (040) 79 33 33.

New Zealand: Philips Electrical Ind. Ltd., Elcoma Division, 70-72 Kingsford Smith Street, WELLINGTON, Tel. 873 156.

Norway: ELECTRONICA A/S., Vitaminveien 11, P.O. Box 29, Grefsen, OSLO 4, Tel. (02) 15 05 90.

Peru: CADESA, Jr. Ilo, No. 216, Apartado 10132, LIMA, Tel. 27 73 17.

Philippines: ELDAC, Philips Industrial Dev. Inc., 2246 Pasong Tamo, MAKATI-RIZAL, Tel. 86-89-51 to 59.

Portugal: PHILIPS PORTUGESA S.A.R.L., Av. Eng. Duharte Pacheco 6, LISBOA 1, Tel. 68 31 21.

Singapore: PHILIPS SINGAPORE PTE LTD., Elcoma Div., POB 340, Toa Payoh CPO, Lorong 1, Toa Payoh, SINGAPORE 12, Tel. 53 88 11.

South Africa: EDAC (Pty.) Ltd., South Park Lane, New Doornfontein, JOHANNESBURG 2001, Tel. 24/6701.

Spain: COPRESA S.A., Balmes 22, BARCELONA 7, Tel. 301 63 12.

Sweden: A. B. ELCOMA, Lidingsövägen 50, S-10 250 STOCKHOLM 27, Tel. 08/67 97 80.

Switzerland: PHILIPS A.G., Elcoma Dept., Edenstrasse 20, CH-8027 ZÜRICH, Tel. 01/44 22 11.

Taiwan: PHILIPS TAIWAN LTD., 3rd Fl., San Min Building, 57-1, Chung Shan N. Rd, Section 2, P.O. Box 22978, TAIPEI, Tel. 5513101-5.

Turkey: TÜRK PHILIPS TICARET A.S., EMET Department, Gümüssuyu Cad. 78-80, Beyoğlu, İSTANBUL, Tel. 45 32 50.

United Kingdom: MULLARD LTD., Mullard House, Torrington Place, LONDON WC1E 7HD, Tel. 01-580 6633.

United States: (Active devices & Materials) AMPEREX SALES CORP., 230, Duffy Avenue, HICKSVILLE, N.Y. 11802, Tel. (516) 931-6200.
(Passive devices) MEPCO/ELECTRA INC., Columbia Rd., MORRISTOWN, N.J. 07960, Tel. (201) 539-2000.
(IC Products) SIGNETICS CORPORATION, 811 East Arques Avenue, SUNNYVALE, California 94086, Tel. (408) 739-7700.

Uruguay: LUZIELECTRON S.A., Rondeau 1567, piso 5, MONTEVIDEO, Tel. 9 43 21.

Venezuela: IND. VENEZOLANAS PHILIPS S.A., Elcoma Dept., A. Ppal de los Ruices, Edif. Centro Colgate, Apdo 1167, CARACAS, Tel. 36 05 11.

© N.V. Philips Gloeilampenfabrieken